

Level Control Valve with Altitude Pilot

Model MN-750-80

Hydraulically operated, diaphragm actuated, control valve that controls reservoir filling and level in response to a hydraulically controlled 3-way altitude pilot, which shuts off the valve at a pre-set reservoir high level, and fully opens the valve when the level drops approximately three foot (one meter).

Bermad 700 Series valves are hydraulic, oblique pattern, globe valves with a seat assembly and double chamber unitized actuator that can be disassembled from the body as a separate integral unit.

The valve's hydrodynamic body is designed for unobstructed flow path and provides high flow capabilities.

The 700 Series operate under difficult operation conditions with minimal cavitation and noise. They are made of the highest quality materials suitable for different mining applications.



Features and Benefits

- Bi-level altitude pilot
 - No float, simple installation
 - ON/OFF Service
 - No cavitation damage
 - Suitable for low quality fluids
 - Reservoir inherent refreshing
- Designed to stand up to the toughest conditions
 - Tamper resistant
 - Drip tight sealing
- Double chamber actuator design
 - Full powered opening and closing (option "B")
 - Protected diaphragm
 - Simplified maintenance as it can be removed as a single unit. In-line serviceable
- Flexible design - Easy addition of optional features
- Obstacle free flow path

Major Additional Features

- Pressure sustaining - **753 - 80**
 - Bi-directional flow - **750 - 87**
 - Full powered opening & closing - **750 - 80 - B**
- See relevant BERMAD publications

List of Components:

- [1] Level Control Valve 750-80
- [2] Strainer 70F
- [3] Combination Air Valve C70

Typical Installation

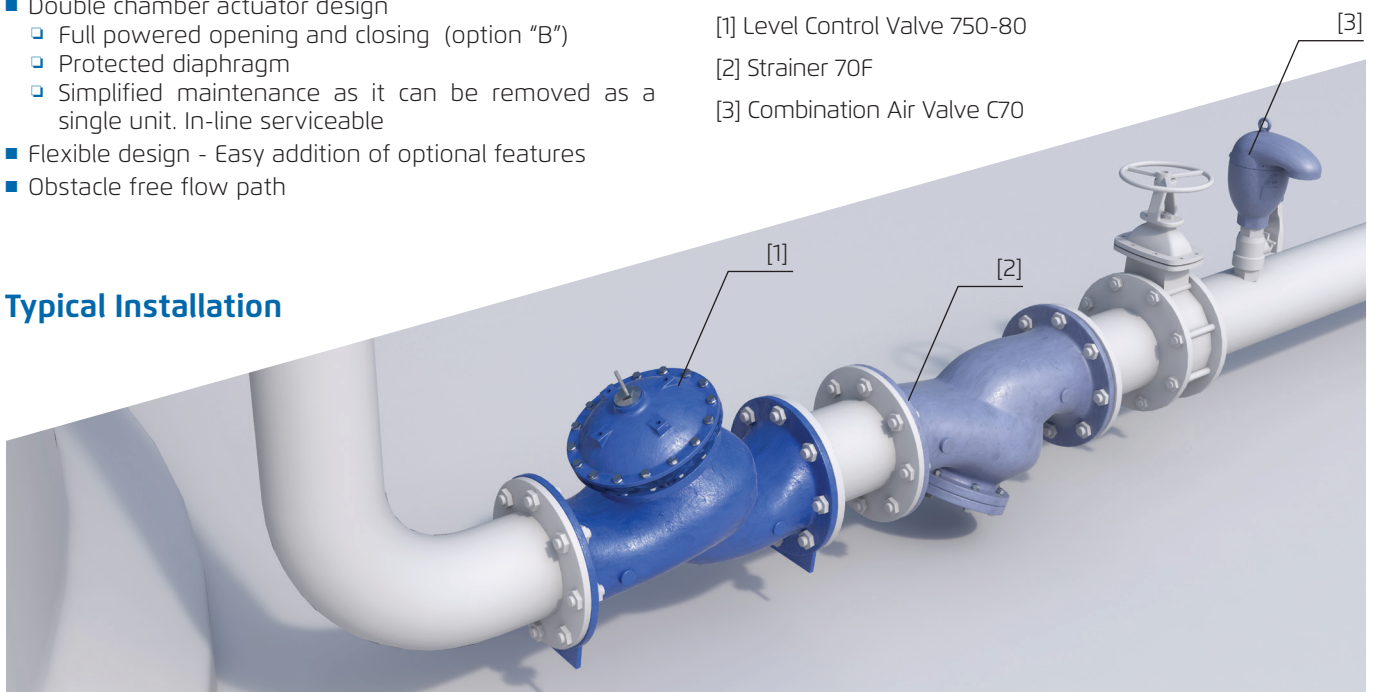



Control Schematic (*)

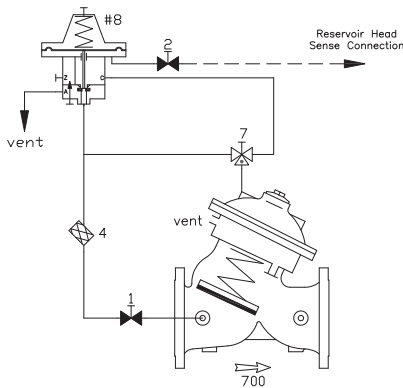

Standard Configuration

- 1 2W Isolation Valve
- 2 2W Isolation Valve
- 4 Control Filter
- 7 3-Way Cock Valve
- #8 3-Way Altitude Pilot

Additional features (OPTIONAL)

- F Large Control Filter
- F1 Extra Large Control Filter
- I Visual Position Indicator
- S Electric Limit Switch

(*) As a reference only. Components may vary based on valve's size and class

Operation

- The main valve is equipped with an adjustable 3-Way altitude pilot. The pilot senses the static head of the reservoir level.
- Should static head rise to the pilot setting, the pilot applies upstream pressure to the upper control chamber, powering the main valve to shut off.
- Should the static head falls below the pilot setting approximately 5 feet (1.5m.), the pilot vents the upper control chamber, causing the main valve to full open.

Altitude Pilot Options:

- Altitude Adjustment Range:

Pilot Code	feet	meter
M6	7-46	2-14
M5	17-72	5-22
M4	49-115	15-35
M8	82-230	25-70

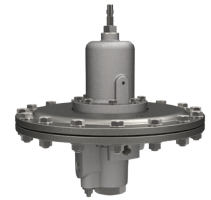

- Shut-off level repeatability: 4" (10 cm.)
- Re-opening level: aprox. 5 ft. (1.5m.) below shut-off level

Pressure Rating

	Class 150			Class 300		
Max. Recommended Pressure	250 PSI			400 PSI		
Available End Connection	Flanged ANSI#150	Grooved ANSI/AWWA C606	Threaded	Flanged ANSI#300	Grooved ANSI/AWWA C606	Threaded

Materials

Components		Water Applications	Thermal Shock Applications	Base Solutions Applications	Acid Solutions Applications (**)
Main Valve	Body & Cover	Ductile Iron	Carbon Steel	Ductile Iron	Stainless Steel 316
	Internals	Stainless Steel	Stainless Steel	Stainless Steel	Stainless Steel 316
		Brass/Coated Steel	Brass/Coated Steel	Coated Steel	
	Elastomers	Synthetic rubber	Synthetic rubber	Synthetic rubber	Viton
Coating	Fusion Bonded Epoxy	Fusion Bonded Epoxy	Fusion Bonded Epoxy	Uncoated	
Pilot	Body	Brass/Bronze	Brass/Bronze	Stainless Steel 316	Stainless Steel 316
	Internals	Stainless Steel	Stainless Steel	Stainless Steel 316	Stainless Steel 316
		Brass	Brass		
Elastomers	Synthetic rubber	Synthetic rubber	Synthetic rubber	Viton	
Control Loop Accessories	Accessories	Brass/Bronze	Stainless Steel 316	Stainless Steel 316	Stainless Steel 316
	Tubing & Fittings	Brass	Stainless Steel 316	Stainless Steel 316	Stainless Steel 316

(**) For highly aggressive acid solutions: Super Duplex, Hastelloy C-276, SMO-254 6-MO. Others by request.

Notes:

- Inlet pressure and flow rate are required for optimal sizing.
- Maximum recommended flow velocity: 6m/sec; 18ft/sec. Intermittent: 7.5m/sec; 21ft/sec.
- Minimum operating pressure: 0.7 bar / 10 PSI. For lower pressure requirements consult factory.

