

COMBINATION AIR VALVE FOR SEWAGE & WASTEWATER

Ductile Iron

Model C80-ER

BERMAD C80 is a high quality combination air valve for a variety of sewage and wastewater networks and operating conditions. It evacuates air during pipeline filling, allows efficient release of air and gas pockets from pressurized pipes, and enables the intake of large volumes of air in the event of network draining. The elongated - body and lower float - is designed to reduce the contact between the fluid and the upper mechanism. With its advanced aerodynamic design, double orifice and Surge Protection device (optional), this valve provides excellent protection against air and gas accumulation and vacuum formation with improved sealing under low pressure conditions. C80 is designed to facilitate longer periods of operation without maintenance and it is easy to maintain.

Features & Benefits

- Straight flow body: Higher than usual flow rates.
- Dynamic Sealing: Prevents leakage under low pressure conditions (0.8 psi; 0.05 bar).
- Elongated body design: Prevents solids from making contact with valve's operating parts.
- Two service ports: Upper and lower 1"; DN20 BSPT or NPT, enabling back flushing and drainage.
- Threaded Side outlet (3"; DN80) for connection of Surge Protection (SP) or Inflow prevention (IP) devices.
- Compact, simple and robust structure with fully corrosion resistant internal parts: Lower maintenance and increased life span.
- Certified to functional standards: SAI AS4883 (Australia).
- Factory approval and Quality Control: Performance and specification tested and measured with specialized test bench, including vacuum pressure conditions.

Typical Applications

- Pumping stations: Air relief and vacuum prevention.
- Non clean water pipelines: Protection against air and gas accumulation and vacuum formation at elevations, slope change points and at road/river crossings.
- Wastewater treatment plants: Air relief, protection against air and gas accumulation and vacuum formation.

Additional Features & Accessories

- Surge Protection (code SP): the kinetic orifice is partially closed during the second stage of the air relief, preventing damage to the air valve and the system and increasing the operational time without maintenance.
- Assisted Closing (code AC): the kinetic orifice is set to be partially closed during air relief.
- Inflow Prevention (code IP): Prevents intake of atmospheric air in cases where this could lead to damaged pumps, required re-priming, or disruption of siphon.
- Drainage Valve (code Z): 1"; DN25 female threaded NPT or BSPT.
- Extension with downwards outlet, 3"; DN80 female threaded.



C80-ER Down Outlet

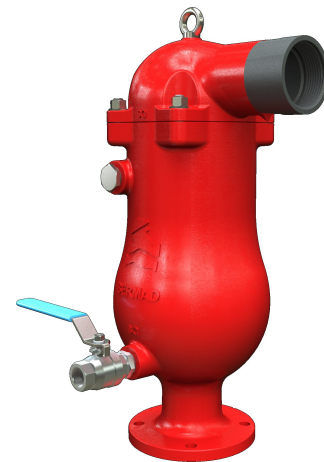

C80-SP-ER Side Outlet



Inlet and Outlet Connections

- Inlets: Flanged 3-4"; DN80-100
- Outlets: Sideways or down, female threaded 3"; DN80

Operational Data

- Pressure Rating: 230 psi, 360 psi
- Minimum operating pressure: 0.8 psi
- Maximum operating pressure: 230 psi, 360 psi
- Media and operating temperature: 33-140°F

Materials

- Body: Ductile Iron
- Cover: Ductile Iron
- Coating: Fusion Bonded Epoxy
- Automatic Orifice: Stainless Steel
- Upper Float Assembly: Polypropylene, Glass-Reinforced Nylon
- Lower Float Assembly: Stainless Steel
- Float Rod: Stainless Steel 316
- Elastomers: NBR, Neoprene
- Plugs for service ports: Stainless Steel 316

Orifice Specifications

Inlet Sizes	Automatic Orifice	Kinetic Orifice		Surge Protection		
	Area	Diameter	Area	Number of holes	Hole Diameter	Total Area
Inch; mm	Sq inch	inch	Sq inch	--	inch	Sq inch
3"-4"; DN80-100	0.029	3	7.069	5	0.236	0.219

Air Flow Performance Charts

Air Relief and Intake (Pipeline Filling, Draining and Vacuum Conditions)

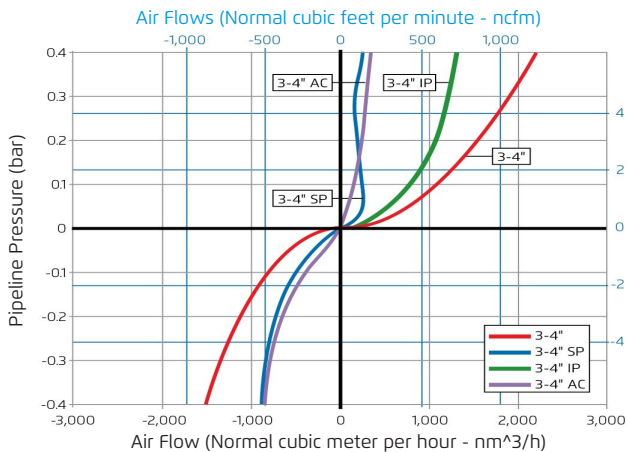

Air Release (Pressurized Operation)

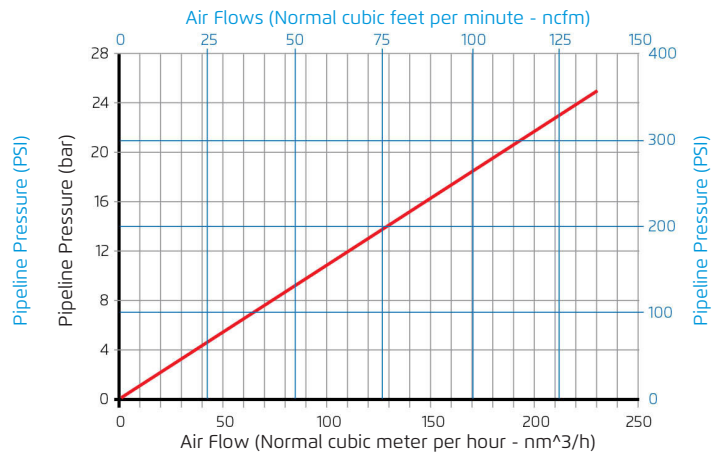

- For higher automatic air release capacity, Please consult with BERMAD.
- Air relief and intake charts are based on actual measurements, measured in Bermad Air Flow test bench, according to EN-1074/4 and AS4883 standard and refer to side outlet. Use Bermad Air software for optimized Sizing & Positioning of Air Valves.

Data for C80-ER with Surge Protection Feature

Inlet Sizes	C80-SP Switching Value	C80-SP Air relief	C80-AC Air relief
	Side Outlet	Side Outlet	Side Outlet
Inch; mm	psi	ncfm	cfm
3"-4"; DN80-100	0.8	171	217



Cutway

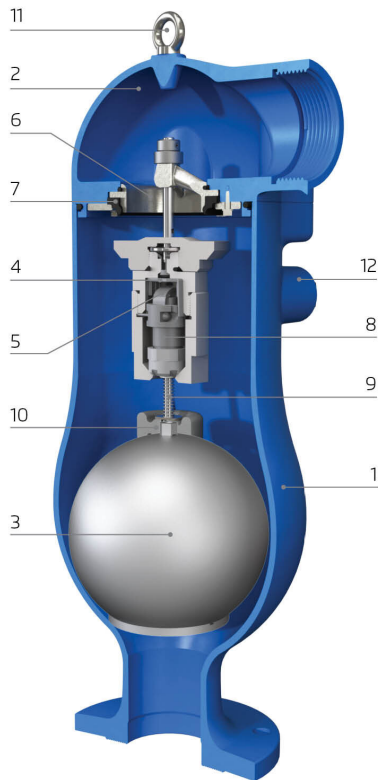

- [1] Body
- [2] Cover
- [3] Float
- [4] Auto Orifice
- [5] Auto Orifice Seal
- [6] Kinetic Orifice
- [7] Kinetic Orifice Seal
- [8] Upper Float Assembly
- [9] Float Rod and Spring
- [10] Shock Absorber
- [11] Eye Bolt
- [12] Upper Service Port

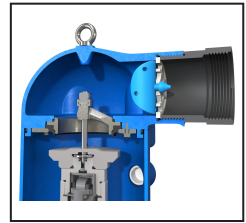

Surge Protection
(code SP)

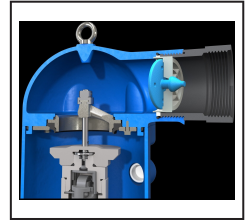

Assisted Closing
(code AC)

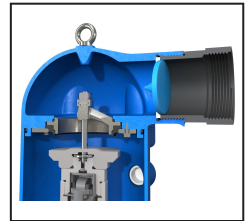

Inflow Prevention
(code IP)

Dimensions & Weights

		With 90 degree elbow (down outlet)			With SP / AC / IP device (side outlet)		
Inlet Sizes	Connection	Width (D)	Height (H)	Weight	Width (D)	Height (H)	Weight
in; mm		in	in	lbs	in	in	lbs
3"; DN80	Flanged	17.480	24.213	61.8	13.189	24.213	60.4
4"; DN100	Flanged	17.480	24.331	65.1	13.189	24.331	63.7

For a height including lifting eye add 1.06"