

# COMBINATION AIR VALVE FOR SEWAGE & WASTEWATER WITH SURGE PROTECTION

Ductile Iron and Glass Reinforced Nylon,  
PN16 / 230 PSI

## Model C50-SP-J-ER

BERMAD C50 is a high quality combination air valve for a variety of sewage and wastewater networks and operating conditions. It evacuates air during pipeline filling, allows efficient release of air and gas pockets from pressurized pipes, and enables large volume air intake in the event of network draining.

With its advanced aerodynamic design, double orifice and Surge Protection device, this valve provides excellent protection against air and gas accumulation and vacuum formation with improved sealing under low pressure conditions.

### Features & Benefits

- Straight flow body: Higher than usual flow rates.
- Elongated body design: Prevents solids from making contact with valve's operating parts.
- Surge Protection: the kinetic orifice is partially closed during the second stage of the air relief, preventing damage to the air valve and the system and increasing the operational time without maintenance.
- Dynamic Sealing: Prevents leakage under low pressure conditions (0.8 psi; 0.05 bar).
- Two service ports: Upper 3/4"; DN20 BSPT and lower 1"; DN25 BSPT, enabling back flushing and drainage.
- Compact and simple structure with fully corrosion resistant internal parts: Lower maintenance and increased life span.
- Certified to functional standards: SAI AS4883 (Australia).
- Factory approval and Quality Control: Performance and specification tested and measured with specialized test bench, including vacuum pressure conditions.

### Typical Applications

- Pumping stations: Air relief, surge protection and vacuum prevention.
- Non clean water pipelines: Protection against air and gas accumulation and vacuum formation at elevations, slope change points and at road/river crossings.
- Wastewater treatment plants: Air relief, protection against air and gas accumulation and vacuum formation.

### Additional Features & Accessories

- Assisted Closing (code AC): the kinetic orifice is set to be partially closed during air relief.
- Inflow Prevention (code IP): Prevents intake of atmospheric air in cases where this could lead to damaged pumps, required re-priming, or disruption of siphon.
- Drainage Valve (code Z): 1"; DN25 female threaded BSP.



C50-J-ER-Threaded with Surge Protection



C50-J-ER-Flanged with Surge Protection and 90 degrees elbow



### Inlet and Outlet Connections

- Inlets: Male threaded 2"; DN50, flanged 2-4"; DN50-100
- Outlets: Sideways, female threaded 2"; DN50
  - Optional addition of extension with 90 degrees elbow

### Operational Data

- Pressure Rating: ISO PN16
- Minimum operating pressure: 0.05 bar
- Maximum operating pressure: 16 bar
- Media and operating temperature: Non clean water, 1-60°C

### Materials

- Body: Ductile Iron
- Coating: Fusion Bonded Epoxy
- Upper Float Assembly: Polypropylene, Glass-Reinforced Nylon
- Lower Float Assembly: Polypropylene. Optional – Stainless Steel 316
- Float Rod: Stainless Steel 316
- Elastomers: EPDM, NBR. Optional – Viton
- Plugs for service ports: Polypropylene

### Orifice Specifications

Inlet Sizes	Automatic Orifice	Kinetic Orifice		Surge Protection / Assisted Closing		
	Area	Diameter	Area	Number of holes	Hole Diameter	Total Area
Inch; mm	Sq mm	mm	Sq mm	--	mm	Sq mm
2"-4"; DN50-100	12.2	45.0	1,590	4	4	50

### Air Flow Performance Charts

**Air Relief and Intake** (Pipeline Filling, Draining and Vacuum Conditions)

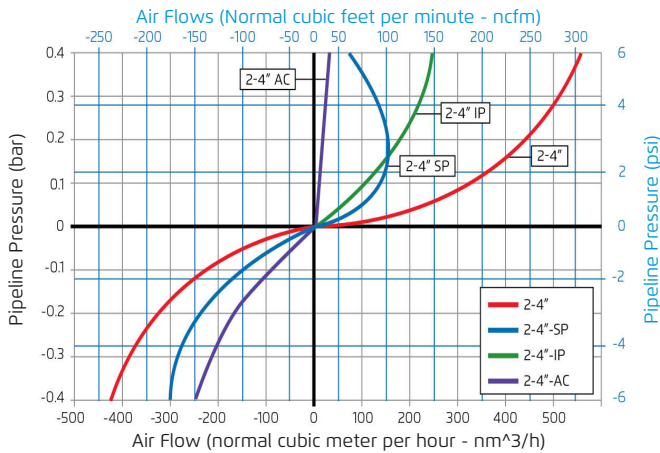

**Air Release** (Pressurized Operation)

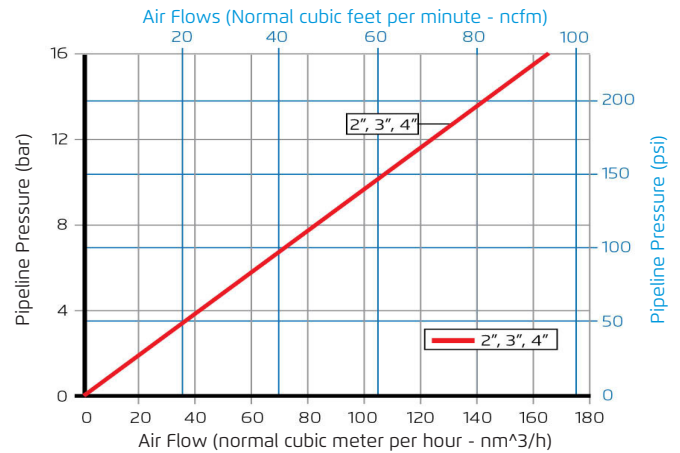

- For higher automatic air release capacity, Please consult with BERMAD.
- Air relief and intake charts are based on actual measurements, measured in Bermad Air Flow test bench, according to EN-1074/4 and AS4883 standard and refer to side outlet. Use Bermad Air software for optimized Sizing & Positioning of Air Valves.



C50-SP-J-ER

### Cutaway

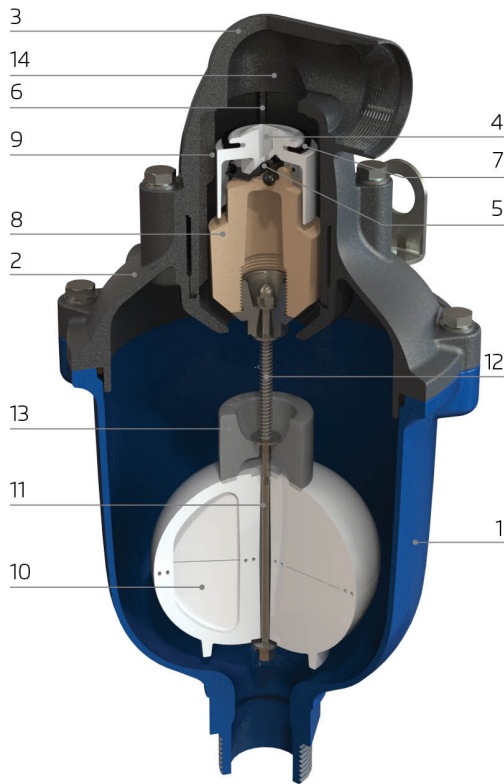

- [1] Body
- [2] Neck
- [3] Cover
- [4] Auto Orifice
- [5] Auto Orifice Seal
- [6] Kinetic Orifice
- [7] Kinetic Orifice Seal
- [8] Upper Float
- [9] Kinetic Plug
- [10] Lower Float
- [11] Float Rod
- [12] Spring
- [13] Shock Absorber
- [14] Insect Screen

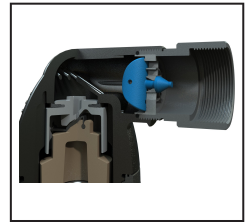

Surge Protection  
(code C50-SP)

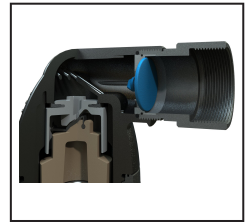

Inflow Prevention  
(code C50-IP)

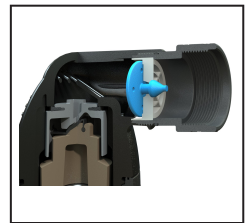

Assisted Closing  
(code C50-AC)



Extension with  
downwards outlet

### Dimensions & Weights

		 C50-J-Threaded with Surge Protection			 C50-J-Flanged with Surge Protection and 90 degrees elbow		
		Width (D)	Height (H)	Weight	Width (D)	Height (H)	Weight
Inlet Sizes	Connection	mm	mm	Kg	mm	mm	Kg
2"; DN50	Threaded	272	489	12.0	---	---	---
2"; DN50	Flanged	---	---	---	380	500	13.7
3"; DN80	Flanged	---	---	---	380	489	15.2
4"; DN100	Flanged	---	---	---	380	490	17.0