

Level Control Valve with Modulating Horizontal Float

(Sizes 1½-16"; DN40-400)

Description

Hydraulically operated control valve that sustains reservoir level

Reservoir filling is accomplished in response to a hydraulically controlled modulating horizontal float that maintains a constant water level, regardless of fluctuating demand.

Installation

1. Ensure enough space around the valve assembly for future maintenance and adjustments
2. Prior to valve installation, flush the pipeline to ensure a flow of clean fluid through the valve
3. For future maintenance, install Isolation Valves upstream and downstream of the control valve
4. Install the valve in the pipeline with the valve flow direction arrow in the actual flow direction. When applicable use the lifting ring provided on the main valve cover for installing the valve
5. For best performance, it is recommended to install the valve horizontally and upright. For different valve positions – consult Bermad
6. It is highly recommended to install a Bermad strainer (model 70F) upstream of the control valve, to prevent debris from damaging the valve's operation
7. Install the float pilot assembly near the reservoir man-hole, at a still place or at an internal stilling tank.
8. Determine the desired float location at the reservoir desired level and up-to 20 Cm above it.
9. Fix the float to the reservoir wall, or other stable element, ensuring the float will remain still in its original orientation.
10. Anchor the float arm position by tightening the arm base screws, using 7/16" spanners.
11. Thread-in the float ball on to the arm and lock it near the edge of the arm, using a 7/16" spanner. Tighten the lock nut.
12. Pull a ½" or ¾" control tube, from the valve to the float.
13. Connect the control tube ends, to the valve and to the float, according to control drawing below, from cock valve [2] to float inlet port.

Commissioning & Calibration

1. Confirm that cock valves [1] and [2] are open (handle parallel to cock-valve body).
2. Confirm that the supply pressure is typical.
3. Adjust the water level by setting the float arm angle: Hold the float arm at its upper position & set the angle to 100 mm below desired upper level (but not higher than 150 mm below over-flow level).
4. Open upstream and downstream isolating valves. Allow the valve to open (ensuring the float ball is at its lower position) and fill-up the reservoir.
5. Vent air from the valve control loop:
During filling the reservoir move the float arm manually to its upper position, forcing the valve to close, then to its lower position, forcing the valve to open. At each position, vent air from the valve control loop by loosening tube fitting at the highest point on the valve & at pilot float inlet port, allowing the air to bleed. Retighten the fittings eyebolts.
6. Calibrating reservoir level:
Ensure that the valve closes as the water level reaches the set-level. If the valve has not closed, change the float arm angle down, to lower level setting or up to raise it, until the valve closes automatically at the desired upper-level. Allow the water level to drop by consuming from the reservoir or by draining it. This will cause the valve to open.
7. The needle valve [5] enables the 2-Way control and controls valve closing speed. It should be set between 1 to 2 turns open, according to valve size, float distance & elevation and the desired closing speed.
8. Cock valve [2] enables manual closing.

Control Drawing

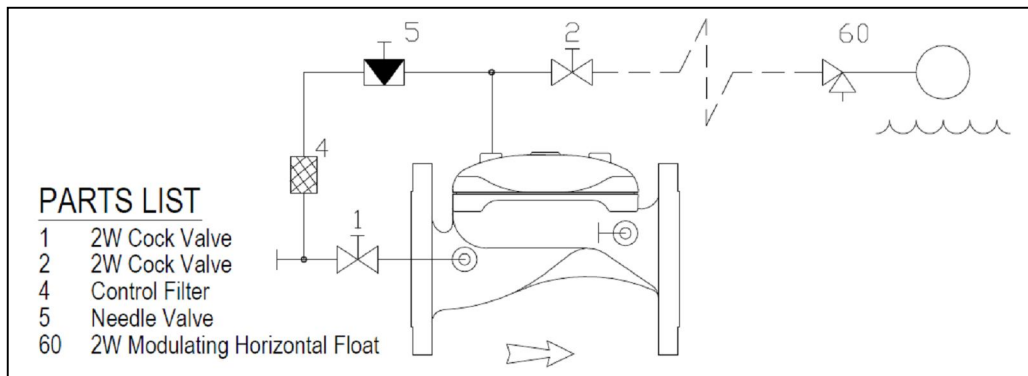

Trouble-Shooting

- Valve fails to Open:** Check for sufficient inlet pressure, confirm float setting & check cock valves status, check needle valve opening rate, confirm control tube length, size & elevation, detect for clogged ports or fittings between valve & float.
- Valve fails to Close:** Confirm float setting, check cock valves status, needle valve opening rate, clean control filter & detect for clogged ports or fittings, check if any debris trapped in the main valve, confirm diaphragm is not leaking.
- Valve fails to Regulate:** Check cock valves status, release air trapped in the valve control chamber.

Preventative Maintenance

- System operating conditions that affect the valve should be checked periodically to determine the required preventative maintenance schedule.
- Maintenance instructions:
 - Tools required:
 - Metric and imperial wrenches
 - Anti seize grease
 - Periodical maintenance
 - Visual inspection to locate leaks and external damage
 - Functional inspection including: closing, opening and regulation
 - 5 yearly scheduled maintenance
 - Close upstream and downstream isolating valves (also close any external sensing pressure when used)
 - Once the valve is fully isolated, vent residual pressure by loosening a plug or fitting
 - Disassemble necessary control hubs, unscrew the cover fastening bolts and remove the cover.
 - Inspect the diaphragm and sealing area on the valve body
 - Replace the diaphragm if worn or damaged
 - Lubricate all threads with Anti seize grease and replace the cover

Spare parts

Bermad has a convenient and easy to use ordering guide for valve spare-parts and control system components at

<http://www.bermad.com/downloads>

For solenoid valves refer to model and S/N on solenoid tags.

Pub #: IOM450-60_10_12

By: PG 10/12

Rev.

File name: IOM450-60_10_12

appliceng@bermad.com • www.bermad.com

The information contained in this document is subject to change without notice.

BERMAD shall not be liable for any errors contained herein. All Rights Reserved. © Copyright by BERMAD Control Valves.