

IR-200 Basic Valve

The BERMAD basic Model IR-200 diaphragm actuated hydraulically operated valve combines simple and reliable construction with good hydraulic performance. These automatic water control valves are designed for vertical or horizontal installation and are available in globe, angle or 'Y' patterns in diameter sizes of 1/2-2"; DN20- DN50.

The IR-200 valves are divided into two main types – Hydraulic Valve and Electric Valve. The Electric Valve control circuit is internal providing some significant benefits such as:

- No external tubes and accessories
- Compact and protected construction
- Self-cleaning orifice for reliable valve operation, even with brackish water.

The Model IR-200 is a durable plastic valve. The valve body, cover, and seal disk assembly construction material uses Glass-Filled Nylon to meet rough service conditions obtaining high chemical and cavitation resistance.

The valve body design includes a full bore seat with unobstructed flow path, free of any in-line ribs, supporting cage, or shafts. Its seal disk assembly includes a flexible, carefully balanced, and peripherally supported diaphragm and a rugged guided plug with elastomeric sealing surface. This internal design enables:

- High flow rate with low head loss
- Smooth valve opening and closing
- Accurate and stable regulation
- Low opening and actuation pressure
- No diaphragm erosion and distortion
- Same diaphragm and spring fully meet the valve's operating pressure range requirements

The Model IR-200 Basic Valve uses valve differential pressure to power the diaphragm assembly open or closed. The lower side of the diaphragm, which serves to cushion the closing of the valve, is exposed to downstream pressure through a peripheral passageway. The pressure in the control chamber varies, resulting from the action of a solenoid or a regulating pilot. This varying pressure modulates the valve to open or close.



BERMAD Irrigation

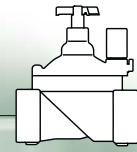

Principle of Operation

200 Series

On-Off Modes, 3-Way Hydraulic Control

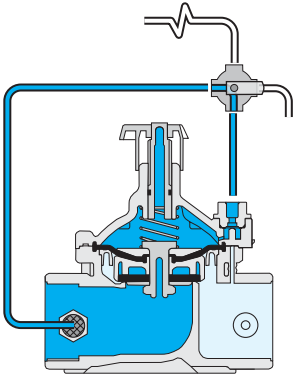

Closed Position

Line pressure applied to the control chamber of the valve creates a superior force that moves the valve to the closed position and provides drip tight sealing.

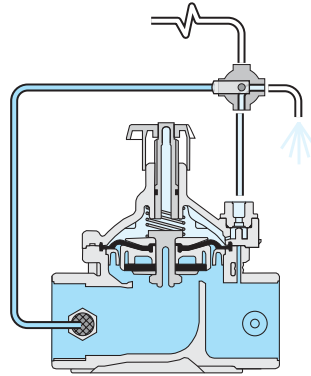

Open Position

Discharging the pressure in the control chamber to atmosphere or, some other lower pressure zone, causes the line pressure acting on the seal disc to move the valve to the open position.

On-Off Modes, 2-Way Solenoid Control

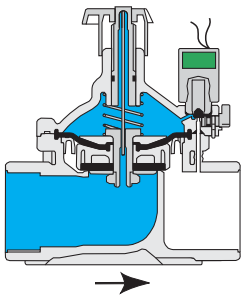

Closed Position

The internal restriction continuously allows line pressure into the control chamber. The solenoid controls outflow from the control chamber. When the solenoid is closed it causes pressure to accumulate in the control chamber, thereby forcing the valve to close.

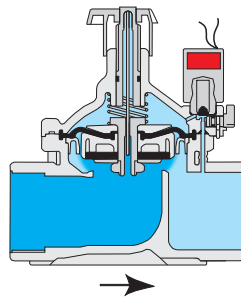

Open Position

Opening the Solenoid releases more flow from the control chamber than the restriction can allow in. This causes the accumulated pressure in the control chamber to drop, enabling the line pressure acting on the plug to the valve.

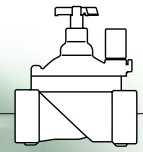

On-off Modes, 3-Way Solenoid Controlled

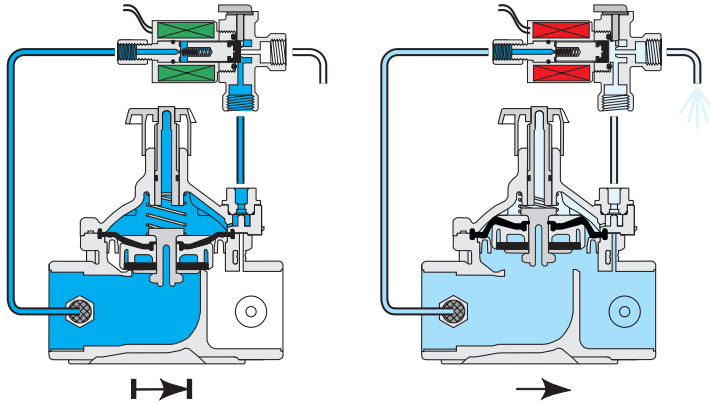

Normally Closed Configuration

The de-energized solenoid applies line pressure to the control chamber, closing the valve. Energizing the solenoid blocks the supply pressure port and opens the drain port, venting the control chamber to the atmosphere. This causes the main valve to open fully.

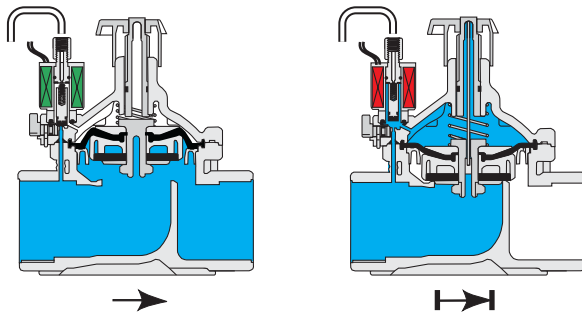

Normally Open Configuration

The de-energized solenoid blocks the valve internal line pressure inlet and opens the drain port, venting the control chamber to the atmosphere, thereby fully opens the valve. Energizing the solenoid opens the internal line pressure inlet and blocks the drain port. This pressurizes the control chamber, closing the valve.

BERMAD Irrigation

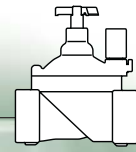

Principle of Operations

200 Series

2-Way Modulating Modes, Pressure Reducing

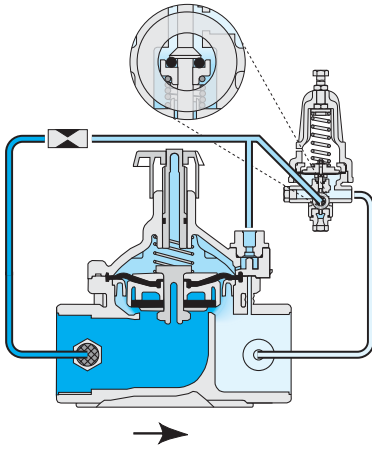

Modulating Closed

The restriction continuously allows line pressure into the control chamber. The pilot controls outflow from the control chamber. Throttling when it senses a pressure rise, it causes pressure to accumulate in the control chamber, thereby forcing the valve to modulate closed.

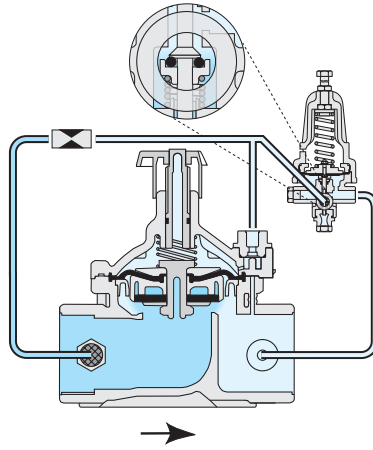

Modulating Open

The pilot modulates open when it senses a pressure drop releasing more flow from the control chamber than the restriction can allow in. This causes the accumulated pressure in the control chamber to drop and the valve modulates open.

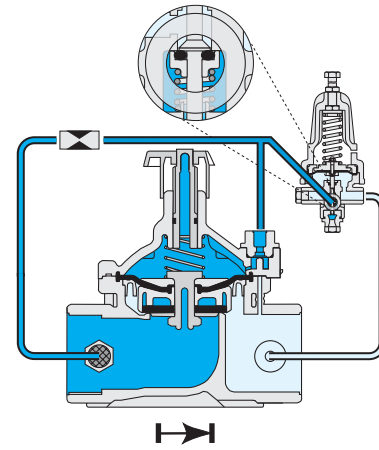

Zero Flow Position

When demand drops to zero, downstream pressure begins to rise as the flow enters a closed line. The pilot closes initiating a valve's irreversible closing process, eventually causing it to seal drip tight.

3-Way Modulating Modes, Pressure Reducing

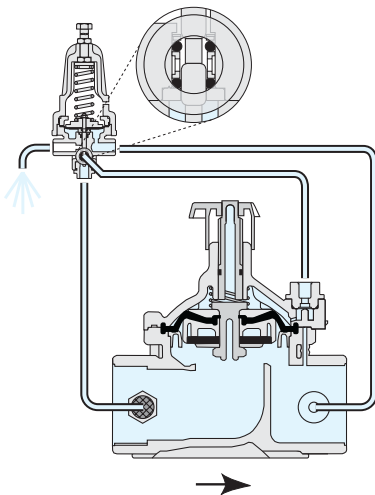

Fully Open Position

When upstream pressure drops, the pilot blocks the pressure port and opens the drain port, venting the control chamber to the atmosphere. This fully opens the valve, minimizing head loss.

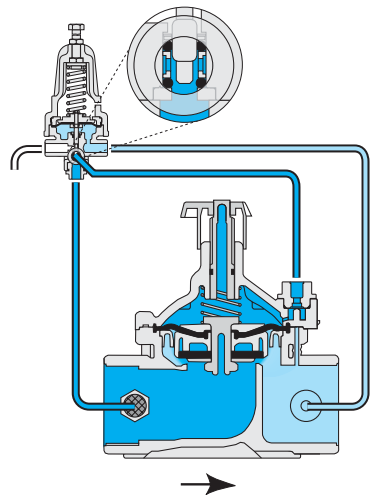

Modulating Closed

The pilot switches upon pressure rise, blocking the drain port and opening the pressure port. This pressurizes the control chamber, forcing the valve to modulate closed.

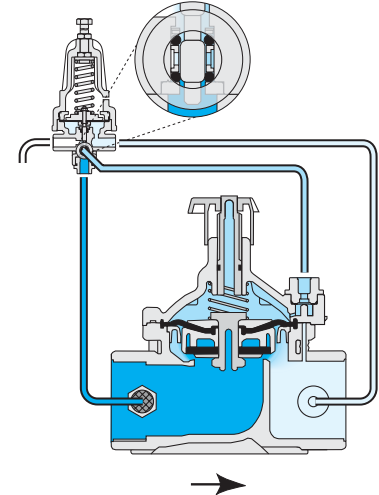

Locked Position

When sensed pressure is equal to setting, the pilot shaft moves and blocks both the drain port and the pressure port. This locks the pressure in the control chamber, freezing the valve in its last position until conditions change.



BERMAD Inc. Tel: 800-821-6825, Fax: 714-666-2533
bermad@bermadusa.com • www.bermad.com

The information herein is subject to change without notice. BERMAD shall not be held liable for any errors. All rights reserved. © Copyright by BERMAD.

BERMAD Irrigation

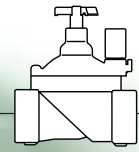

Product Parts Features, Hydraulic Valve

200 Series

[1] Fastening Bolts & Nuts

6 Stainless Steel bolts and nuts (1½-2"; DN40-50 valves) fasten valve cover to body, ensuring quick in-line inspection and service.

[2] Valve Cover (Hydraulic Type)

Simple and light construction enables quick in-line inspection and service.

[2.1] Flow Stem (Optional)

[3] Auxiliary Closing Spring

One single spring fully meets valve requirements for operating pressure range, ensuring low opening pressure and secured closing.

[4] Seal Disk Assembly (Hydraulic Type)

The seal disk assembly includes a flexible, carefully balanced, and peripherally supported diaphragm and a rugged guided plug with elastomeric sealing surface. This internal design enables:

- High flow rate with low head loss
- Smooth valve opening and closing
- Accurate and stable regulation
- Low opening and actuation pressure
- No diaphragm erosion and distortion
- Same diaphragm and spring fully meet the valve's operating pressure range requirements

[5] Diaphragm Supporting Ring

[6] Valve Body (Hydraulic Type)

Glass-Filled Nylon to meet rough service conditions obtaining high chemical and cavitation resistance. Full bore seat with unobstructed flow path, free of any in-line ribs, supporting cage, or shafts.

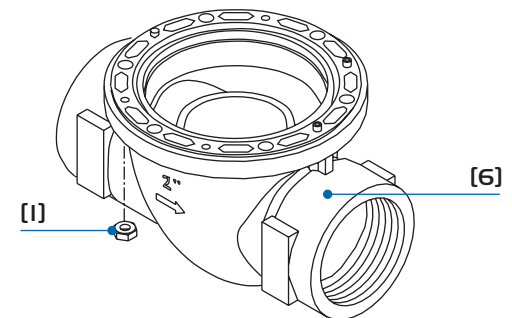
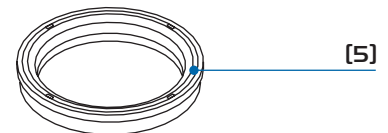
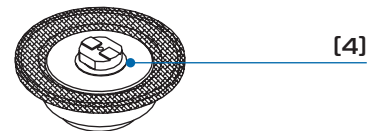
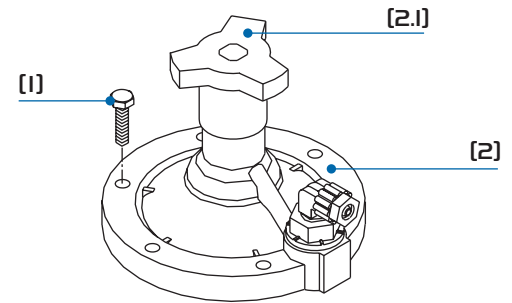

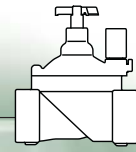

[1] Fastening Bolts & Nuts

6 Stainless Steel bolts and nuts (1 1/2"-2"; DN40-50 valves) fasten valve cover to body, ensuring quick in-line inspection and service.

[2] Valve Cover (Electric Type)

Simple and light construction enables quick in-line inspection and service.

[2.1] 2-Way Solenoid Actuator

[2.2] Manuale Override Handle

[2.3] Needle - Restricts inlet flow & eliminates internal restriction clogging.

[2.4] Flow Stem (optional)

[3] Auxiliary Closing Spring

One single spring fully meets valve requirements for operating pressure range, ensuring low opening pressure and secured closing.

[4] Seal Disk Assembly (Electric Type)

The seal disk assembly includes a flexible, carefully balanced, and peripherally supported diaphragm and a rugged guided plug with elastomeric sealing surface. This internal design enables:

- High flow rate with low head loss
- Smooth valve opening and closing
- Accurate and stable regulation
- Low opening and actuation pressure
- No diaphragm erosion and distortion
- Same diaphragm and spring fully meet the valve's operating pressure range requirements

[4.1] Internal Restriction

[5] Diaphragm Supporting Ring

[6] Valve Body (Electric Type)

Glass-Filled Nylon to meet rough service conditions obtaining high chemical and cavitation resistance. Full bore seat with unobstructed flow path, free of any in-line ribs, supporting cage, or shafts.

[6.1] Internal Control Circuit Outlet

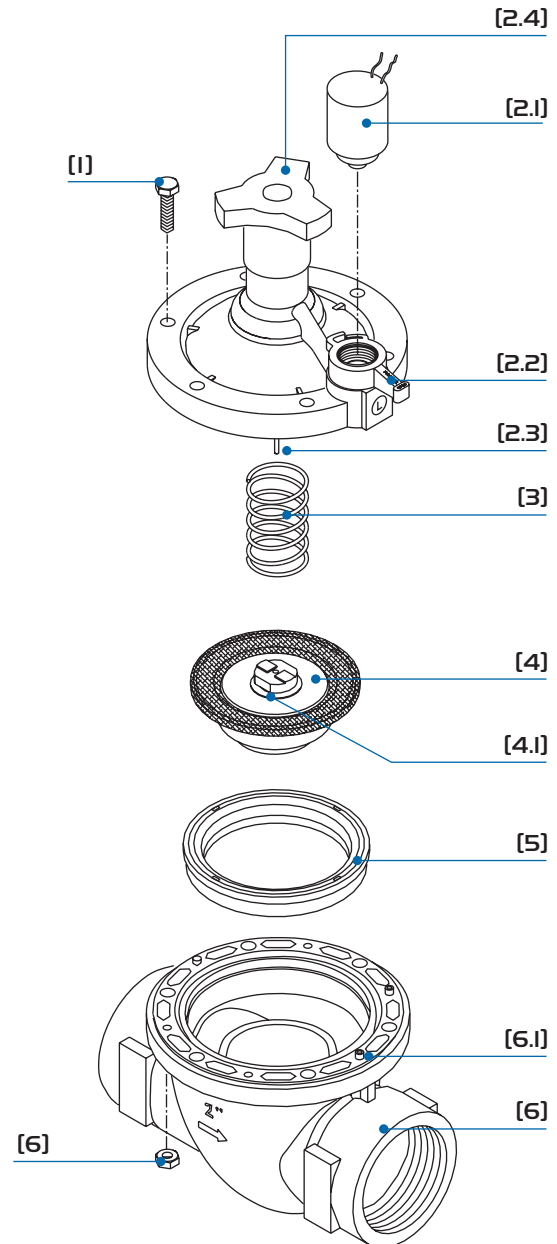

BERMAD Irrigation

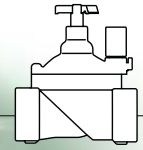

Technical Data

200 Series



Dimensions & Weights

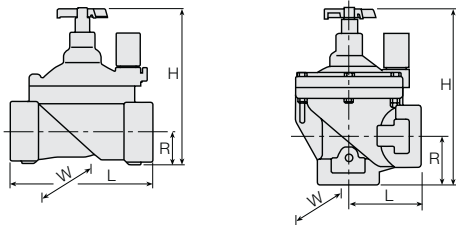

Pattern Size	Globe				Angle	
	3/4"	1"	1 1/2"	2"	1 1/2"	2"
L (inch)	45/16	45/16	65/16	611/16	33/16	33/8
H (inch)	4 1/2	4 1/2	7 1/8	7 1/2	7 1/2	8 1/4
R (inch)	7/8	7/8	13/8	1 1/2	19/16	23/8
W (inch)	31/16	31/16	415/16	415/16	45/16	415/16
Weight* (lb)	0.77	0.73	2.2	2.4	2.1	2.0
CCDV** (gal)	0.004	0.004	0.02	0.02	0.02	0.02

* Without flow control handle

**Control Chamber Displacement Volume (gallons)

Technical Specifications

Available Patterns & Sizes:

Globe: 3/4", 1", 1 1/2", 2"

Angle: 1 1/2", 2"

Available End Connections:

BSP-T; NPT female threads

Pressure Rating: 150 psi

Operating Pressure Range: 10-150 psi

Temperature: Water up to 140°F

Standard Materials:

- Body & Cover: Nylon Reinforced
- Metal Parts: Stainless Steel
- Diaphragm: Natural Rubber
- Seals: NBR [Buna-N]
- Spring: Stainless Steel
- Cover bolts: Stainless Steel

Flow Chart

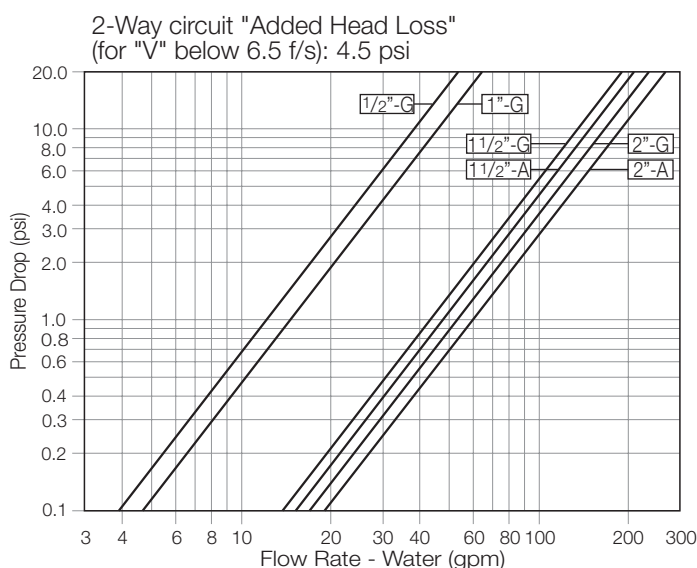

BERMAD Inc. Tel: 800-821-6825, Fax: 714-666-2533
bermad@bermadusa.com • www.bermad.com

The information herein is subject to change without notice. BERMAD shall not be held liable for any errors. All rights reserved. © Copyright by BERMAD.

