



PRESSURE REDUCING VALVE

Model IR-120-3W-XZ

The BERMAD Pressure Reducing Valve is a hydraulically operated, diaphragm actuated control valve that reduces higher upstream pressure to lower constant downstream pressure and opens fully upon line pressure drop.



- [1] BERMAD Model IR-120-3W-XZ establishes reduced pressure zone, protecting laterals and distribution line.
- [2] Combination Air Valve Model IR-C10
- [3] Combination Air Valve Model IR-C30

Features & Benefits

- Line Pressure Driven, Hydraulically Controlled
 - Protects downstream systems
 - Opens fully upon line pressure drop
- Engineered Composite Valve with Industrial Grade Design
 - Adaptable on-site to a wide range of end connection
 - Articulated flange connections that eliminate line bending and hydraulic stresses
 - Highly durable, chemical and cavitation resistant
- hYflow 'Y' Valve Body with "Look Through" Design
 - Ultra-high flow capacity at low pressure loss
- Unitized "Flexible Super Travel" (FST) Diaphragm and Guided Plug
 - Accurate and stable regulation with smooth closing
 - Requires low actuation pressure
 - Prevents diaphragm erosion and distortion
 - Simple in-line inspection and service

Typical Applications

- Automated Irrigation Systems
- Pressure Reducing Systems
- Systems Subject to Varying Supply Pressure
- Distribution Centers
- Energy Saving Irrigation Systems

Operation:

The Pressure Reducing Pilot [1] commands the main valve to throttle closed should Downstream Pressure [P2] rise above pilot setting, and to open fully when it drops below pilot setting. The Manual Selector [2] enables local manual closing.

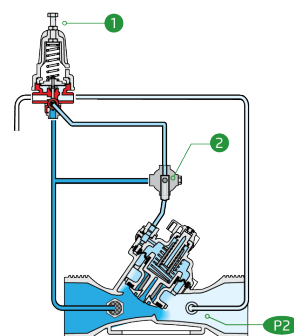



Technical Data

Pressure Rating:
10 bar

Operating Pressure Range:
0.5-10 bar

Materials

Body & Cover:
Polyamide 6 & 30% GF

Diaphragm:
NR, Nylon fabric reinforced

Spring:
Stainless Steel

Control Loop Accessories

PR Pilot: PC-SHARP-X-P

Pilot Spring Range:

Spring	Spring Color	Setting range
J	Green	0.2-1.7 bar
K	Gray	0.5-3.0 bar
N	Natural	0.8-6.5 bar
V	Blue & White	1.0-10.0 bar

Standard spring - marked in bold

Tubing and Fittings:

Polyethylene and Polypropylene

Technical Specifications

For other patterns and end connection types, Please refer to [BERMAD](#) full engineering page.

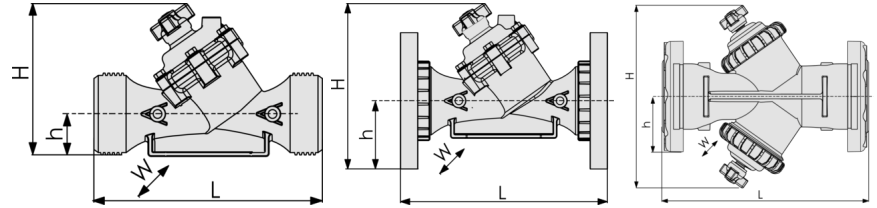

Size	Pattern	End Connection	Weight (Kg)	L (mm)	H (mm)	h (mm)	w	CCDV (Lit)	KV
1½" ; DN40	Oblique	Threaded	1.1	200	173	40	97	0.12	50
2" ; DN50	Oblique	Threaded	1.2	230	173	40	97	0.12	50
2"L ; DN50L	Oblique	Threaded	1.5	230	187	43	135	0.15	100
2½" ; DN65	Oblique	Threaded	1.5	230	187	43	135	0.15	100
3" ; DN80	Oblique	Threaded	1.6	298	199	55	135	0.15	100
3" ; DN80	Oblique	Plastic Flanges	2.5	308	244	100	200	0.15	100
3" ; DN80	Oblique	Metal Flanges	4.4	308	244	100	200	0.15	100
3"L ; DN80L	Oblique	Threaded	3	298	278	60	168	0.62	200
3"L ; DN80L	Oblique	Plastic Flanges	3.7	308	317	100	200	0.62	200
3"L ; DN80L	Oblique	Metal Flanges	4.6	308	317	100	200	0.62	200
4" ; DN100	Oblique	Plastic Flanges	4.6	350	329	112	224	0.62	200
4" ; DN100	Oblique	Metal Flanges	7.4	350	329	112	224	0.62	200
4"L ; DN100L	Oblique	Plastic Flanges	9.2	442	340	112	226	1.15	340
4"L ; DN100L	Oblique	Metal Flanges	11.2	442	340	112	226	1.15	340
6"R ; DN150R	Oblique	Metal Flanges	16.5	470	377	149	287	1.15	340
6" ; DN150	Boxer	Grooved	11	480	387	100	475	2x0.62	400
6" ; DN150	Boxer	Plastic Flanges	12.5	504	387	143	475	2x0.62	400

CCDV = Control Chamber Displacement Volume • **Threaded** = BSP & NPT are available. External thread is available for 2" and 2½" only. • Other End Connections are available on request. For dimensions and weights of adapters or valves with adapters please consult with customer service.

Optional Features

Code	Description	Size Range
M	Flow Stem ¹ Exclude sizes 4" L / 10"	1½"-6" / DN40-150
5	Plastic Test Point	1½"-4" / DN40-100
IR-120-3W-XZ	Victaulic PVC Adaptors 3"	3" / DN80
V4	Victaulic PVC Adaptors 4"	4" / DN100

Flow Chart

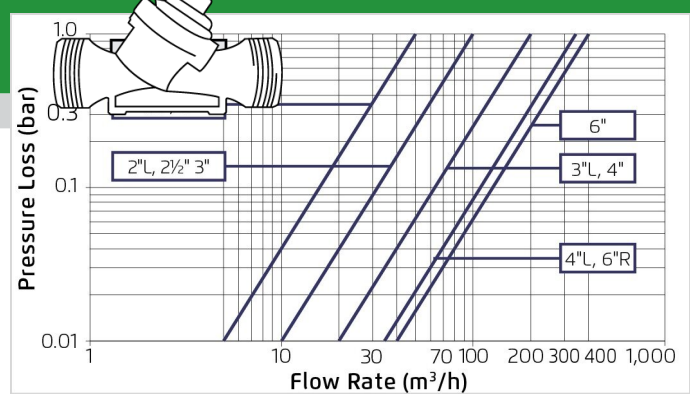

Differential Pressure & Flow Calculation

$$\Delta P = \left(\frac{Q}{Kv} \right)^2$$

Kv = m³/h @ ΔP of 1 bar

Q = m³/h

ΔP = bar

