



PRESSURE REDUCING VALVE

Model IR-120-50-3W-XZ

The BERMAD Pressure Reducing Valve with hydraulic control is a hydraulically operated, diaphragm actuated control valve that reduces higher upstream pressure to lower constant downstream pressure and opens fully upon line pressure drop. It either opens or shuts in response to a remote pressure command.



- [1] BERMAD Model IR-120-50-3W-XZ opens upon pressure drop command, and establishes reduced pressure zone protecting laterals and distribution line.
- [2] Hydrometer Model IR-900-M0-Magnetic Drive
- [3] Combination Air Valve Model IR-C10
- [4] Combination Air Valve Model IR-C30
- [5] Smart Irrigation Controller-OMEGA

Features & Benefits

- Line Pressure Driven, Hydraulically Controlled
 - Protects downstream systems
 - Opens fully upon line pressure drop
- Engineered Composite Valve with Industrial Grade Design
 - Adaptable on-site to a wide range of end connection
 - Articulated flange connections that eliminate line bending and hydraulic stresses
 - Highly durable, chemical and cavitation resistant
- hYflow 'Y' Valve Body with "Look Through" Design
 - Ultra-high flow capacity at low pressure loss
- Unitized "Flexible Super Travel" (FST) Diaphragm and Guided Plug
 - Accurate and stable regulation with smooth closing
 - Requires low actuation pressure
 - Prevents diaphragm erosion and distortion
 - Simple in-line inspection and service

Typical Applications

- Automated Irrigation Systems
- Pressure Reducing Systems
- Systems Subject to Varying Supply Pressure
- Distribution Centers
- Energy Saving Irrigation Systems

Operation:

The Shuttle Valve [1] hydraulically connects the Pressure Reducing Pilot (PRP) [2] to the Valve Control Chamber [3]. The PRP commands the valve to throttle closed should Downstream Pressure [P2] rise above setting and to open fully when it drops below setting. Upon pressure rise command, the shuttle valve automatically switches, allowing pressurization of the control chamber, which causes the main valve to shut. The Manual Selector [4] enables manual closing.

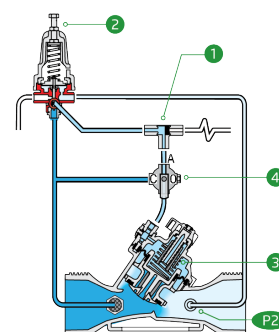



Technical Data

Pressure Rating:
10 bar

Operating Pressure Range:
0.5-10 bar

Materials

Body & Cover:
Polyamide 6 & 30% GF

Diaphragm:
NR, Nylon fabric reinforced

Spring:
Stainless Steel

Control Loop Accessories

PR Pilot: PC-SHARP-X-P

Pilot Spring Range:

Spring	Spring Color	Setting range
J	Green	0.2-1.7 bar
K	Gray	0.5-3.0 bar
N	Natural	0.8-6.5 bar
V	Blue & White	1.0-10.0 bar

Standard spring - marked in bold

Tubing and Fittings:

Polyethylene and Polypropylene

Technical Specifications

For other patterns and end connection types, Please refer to [BERMAD](#) full engineering page.

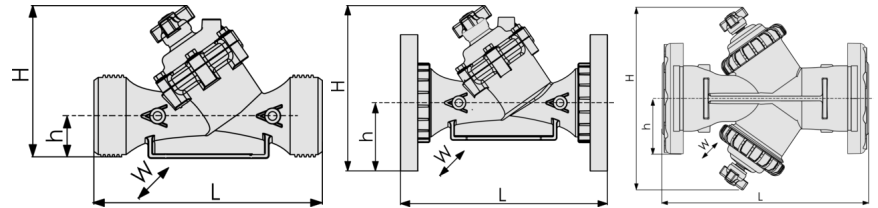

Size	Pattern	End Connection	Weight (Kg)	L (mm)	H (mm)	h (mm)	W	CCDV (Lit)	KV
1½" ; DN40	Oblique	Threaded	1.1	200	173	40	97	0.12	50
2" ; DN50	Oblique	Threaded	1.2	230	173	40	97	0.12	50
2"L ; DN50L	Oblique	Threaded	1.5	230	187	43	135	0.15	100
2½" ; DN65	Oblique	Threaded	1.5	230	187	43	135	0.15	100
3" ; DN80	Oblique	Threaded	1.6	298	199	55	135	0.15	100
3" ; DN80	Oblique	Plastic Flanges	2.5	308	244	100	200	0.15	100
3" ; DN80	Oblique	Metal Flanges	4.4	308	244	100	200	0.15	100
3"L ; DN80L	Oblique	Threaded	3	298	278	60	168	0.62	200
3"L ; DN80L	Oblique	Plastic Flanges	3.7	308	317	100	200	0.62	200
3"L ; DN80L	Oblique	Metal Flanges	4.6	308	317	100	200	0.62	200
4" ; DN100	Oblique	Plastic Flanges	4.6	350	329	112	224	0.62	200
4" ; DN100	Oblique	Metal Flanges	7.4	350	329	112	224	0.62	200
4"L ; DN100L	Oblique	Plastic Flanges	9.2	442	340	112	226	1.15	340
4"L ; DN100L	Oblique	Metal Flanges	11.2	442	340	112	226	1.15	340
6"R ; DN150R	Oblique	Metal Flanges	16.5	470	377	149	287	1.15	340
6" ; DN150	Boxer	Grooved	11	480	387	100	475	2x0.62	400
6" ; DN150	Boxer	Plastic Flanges	12.5	504	387	143	475	2x0.62	400

CCDV = Control Chamber Displacement Volume • **Threaded** = BSP & NPT are available. External thread is available for 2" and 2½" only. • Other End Connections are available on request. For dimensions and weights of adapters or valves with adapters please consult with customer service.

Optional Features

Code	Description	Size Range
M4	Flow Stem ¹ Exclude sizes 4" L (10)	1½"-6" / DN40-150
5	Plastic Test Point	1½"-4" / DN40-100
IR-120-50	3W PVC Adaptors 3"	3" / DN80
V4	Victaulic PVC Adaptors 4"	4" / DN100

Flow Chart

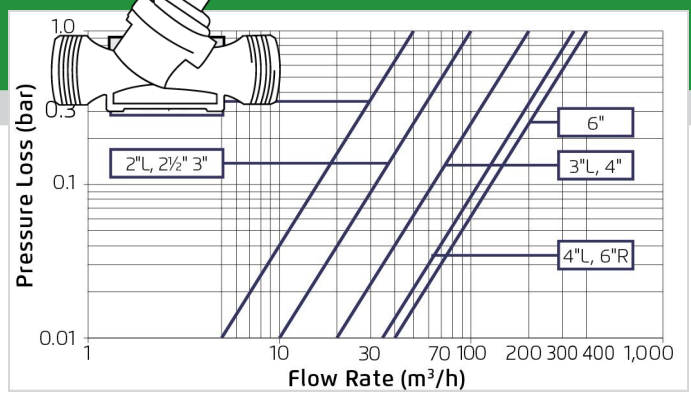

Differential Pressure & Flow Calculation

$$\Delta P = \left(\frac{Q}{Kv} \right)^2$$

Kv = m³/h @ ΔP of 1 bar

Q = m³/h

ΔP = bar

