

Irrigation



BERMAD Irrigation

100 Series - h_{yflow} High Performance Valves

Water Control Solutions



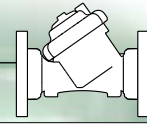

100 Series hYflow

High Performance Plastic Hydraulic Control Valves

Features and Benefits

- **Durable industrial grade** valve design and construction uses glass-filled Nylon material to **meet rough service conditions**.
- **Ultra-high flow capacity** with minimal pressure loss.
- **Designed for service on a wide range of pressure and flow conditions**, from dripping to maximum flow.
- Simple design with few parts **guarantees easy in-line inspection and service**.
- **Positive guided valve plug** provides **accurate motion and smooth regulation**. Avoids chattering and slamming closed.
- **Versatile end connections** allow mix of different sizes and connection types. Female thread, Flanged or PVC 'Slip-on' Glue or Grooved adapter (as add-on option).
- **Articulated flange connections** **isolate** the valve from line bending and pressure stresses



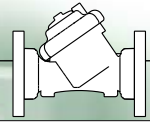

IR-100 hYflow

The BERMAD IR-100 hYflow basic model diaphragm actuated, hydraulically operated valve is at the leading edge of control valve design. It combines simple and reliable construction with superior performance, while at the same time being virtually free of the typical limitations associated with standard control valves.

BERMAD's automatic water control valves are designed for vertical or horizontal installation and are available in sizes of 1½", 2", 2"L, 2½", 3", 3"L, 4" & 6" DN: 40, 50, 50L, 65, 80, 80L, 100 & 150.

The IR-100 hYflow model, made from industrial durable glass-filled nylon, is engineered to meet rough service conditions with high chemical and cavitation resistance. The hYflow 'Y' valve body design includes a full bore seat with unobstructed flow path, free of any in-line ribs, supporting cage, or shafts.

Its unitized Flexible Super Travel (FST) diaphragm and guided plug provide a significantly 'look through' passage from end to end resulting in ultra-high flow capacity with minimal pressure loss.

The combination of a long travel guided valve plug, peripherally supported diaphragm, and replaceable valve seal provides:

- No chattering or slamming closed
- Accurate and stable regulation with smooth motion
- Low operating pressure requirements
- No diaphragm erosion and distortion
- Diaphragm and spring fully meet the valve's operating pressure range requirements
- No UV and frozen effect
- Chemical resistant

Designed for service under a wide range of pressure and flow conditions, from dripping to maximum flow, the IR-100 hYflow excels at being a userfriendly control valve:

- Simple design with few parts guarantees easy in-line inspection and service.
- Adaptable on-site to a wide range of end connection types and sizes.
- Articulated flange connections isolate the valve from pipeline bending and pressure stresses.

"Look-through Design"

Straight through flow results in ultra-high flow capacity with minimum pressure loss

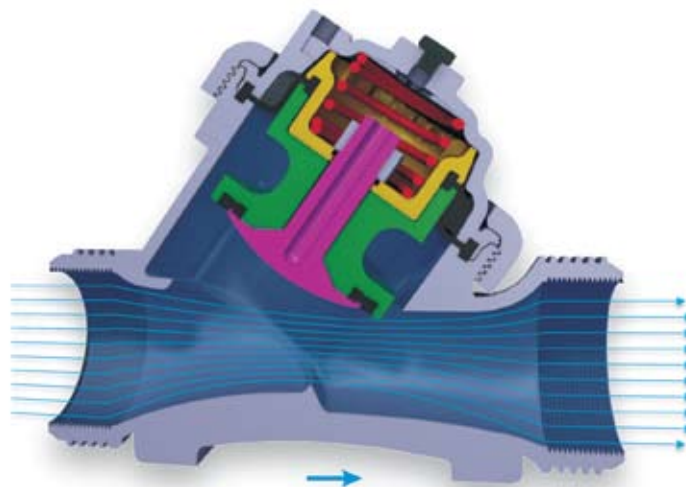

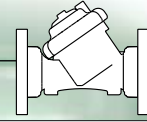

On-Off Modes

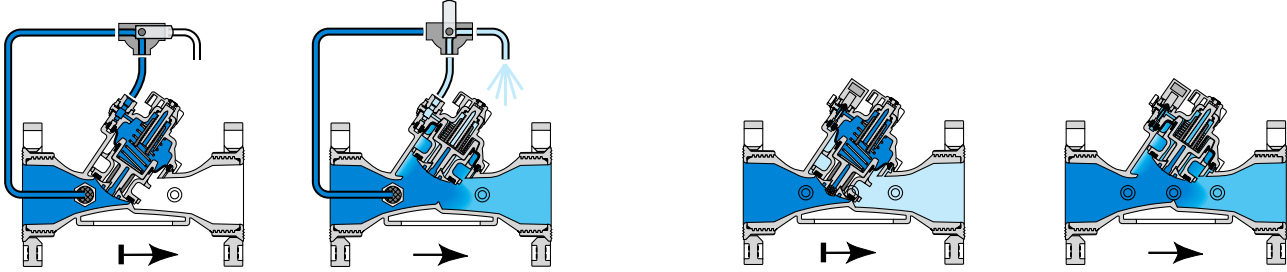

3-Way Control

Line pressure applied to the control chamber of the valve creates a hydraulic force that moves the valve to the closed position and provides drip tight sealing. Discharging pressure from the control chamber to the atmosphere causes the line pressure under the plug to open the valve.

2-Way Internal Control

Line pressure enters the control chamber through the internal restriction. The closed solenoid causes pressure to accumulate in the control chamber, thereby shutting the valve. Opening the Solenoid releases more flow from the control chamber than the restriction can allow in. This causes pressure in the control chamber to drop, allowing the valve to open.

2-Way Modulating Modes (Pressure Reducing Pilot)

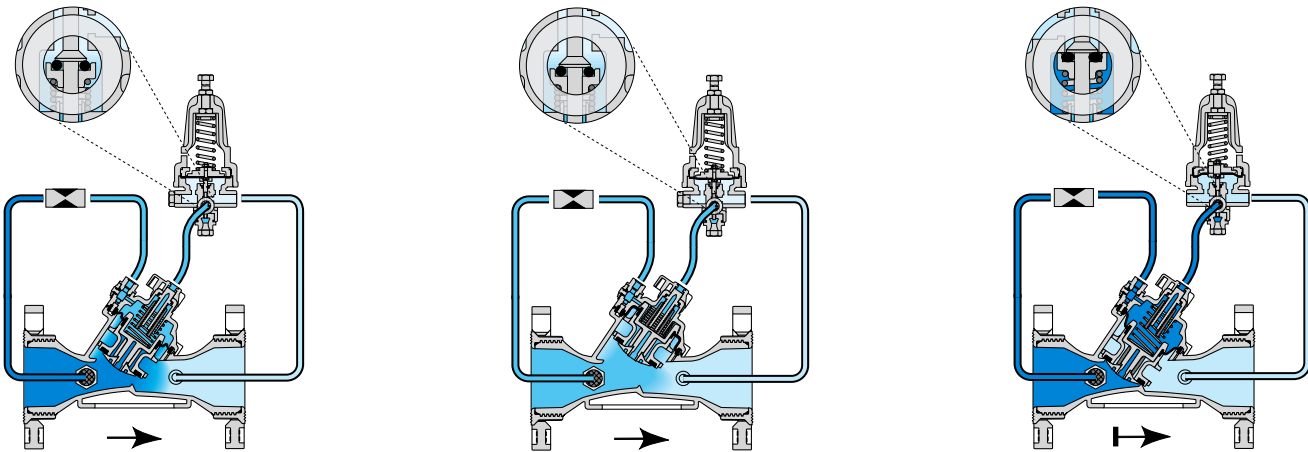

Modulating to Close

Line pressure enters the control chamber through the internal restriction. The pilot controls outflow from the control chamber. Throttling when it senses a pressure rise, it causes pressure to accumulate in the control chamber, thereby forcing the valve to modulate closed.

Modulating to Open

The pilot modulates open when it senses a pressure drop, releasing more flow from the control chamber than the restriction can allow in. This causes the accumulated pressure in the control chamber to drop and the valve modulates open.

Zero Flow Position

When demand drops to zero, downstream pressure begins to rise as the flow enters a closed line. The pilot closes, initiating the valve's irreversible closing process, eventually causing it to seal drip tight.

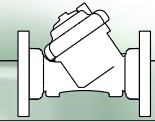

3-Way Control Modes (Pressure Reducing)

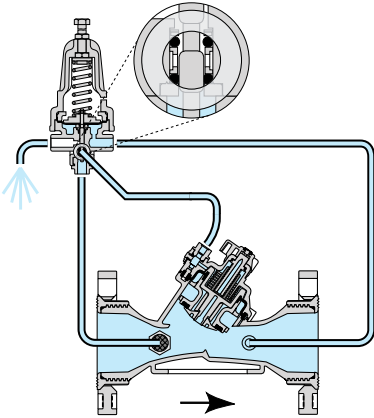

Fully Open Position

When upstream pressure drops, the pilot blocks the supply pressure port and opens the drain port, venting the control chamber to the atmosphere. This fully opens the valve, minimizing head loss.

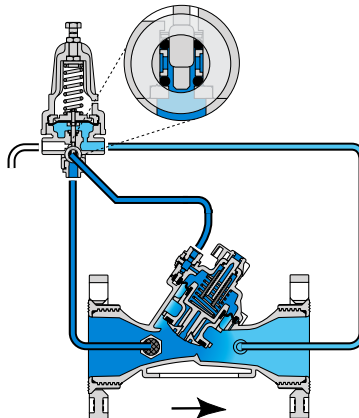

Modulating to Close

The pilot switches upon pressure rise, blocking the drain port and opening the supply pressure port. This pressurizes the control chamber, forcing the valve to modulate closed.

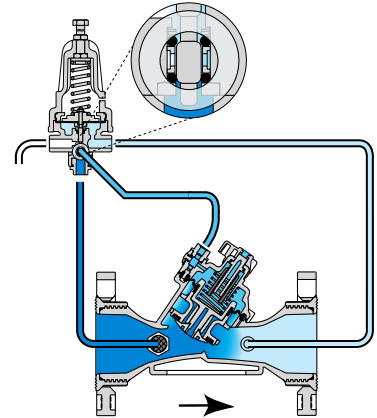

Locked Position

When sensed pressure is equal to setting, the pilot blocks both the drain and the supply pressure ports. This locks the pressure in the control chamber, freezing valve opening in its last position until conditions change.

3/2-Way Control Modes (Pressure Reducing)

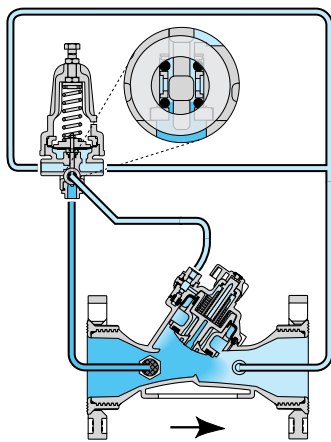

Modulating to Open

When pressure drops, the pilot restricts the flow path through the supply pressure port, and widens the flow path through the drain port. This releases more flow from the control chamber than can be allowed in, thereby causing the valve to modulate open.

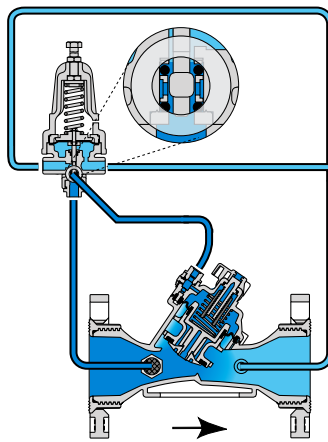

Modulating to Close

Upon pressure rise, the pilot widens the flow path through the supply pressure port, and restricts the flow path through the drain port. This allows more flow into the control chamber than can be released, thereby pressurizing it and forcing the valve to modulate closed.

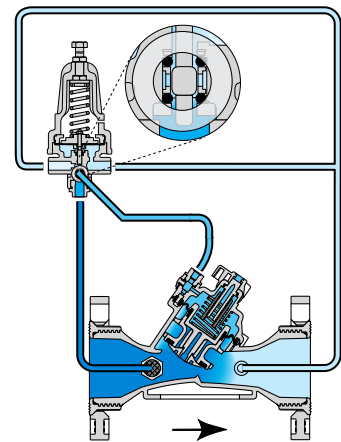

Stable Conditions

As long as flow and pressure conditions are constant, the pilot freezes the control chamber inlet and outlet flow ratio. This keeps the valve opening rate constant, allowing the valve to react "on-line" to any anticipated changes in supply and/or demand conditions.

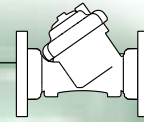

Product Features

[1] Cover Ring

The cover ring fastens valve cover to body, stiffening and strengthening the valve body, enabling simple maintenance. A cover ring key is available.

[2] Pilot Adaptor

The pilot adaptor allows us to connect the mini-pilot valve or the Galit hydraulic relay to the valve body.

[3] Valve Cover

The cover's strong construction meets rough service conditions. Optional cover types (3"; DN80 and smaller valves) are capable of accepting a Flow Stem, a Flow Stem + Position Indicator, and a 2-Way Solenoid (2W-N1 Electric Type).

[4] Auxiliary Closing Spring

One single high grade stainless steel spring provides a wide operation range, ensuring low opening pressure and secured closing.

[5] Plug Assembly

The unitized Flexible Super Travel (FST) plug assembly combines a long travel guided valve plug, peripherally supported diaphragm, and replaceable diaphragm and valve seal. The diaphragm fully meets the valve's operating pressure range requirements.

[5.1] Diaphragm Holder

[5.2] Diaphragm

[5.3] Plug

[5.4] Plug Seal

[6] hYflow 'Y' Valve Body

Glass-filled nylon construction meets rough service conditions with high chemical and cavitation resistance.

End-to-end "look-through" design and full bore seat with unobstructed flow path, free of any in-line ribs, supporting cage, or shafts, enables ultra-high flow capacity with minimal pressure loss.

[7] End Connections

Adaptable on-site to a wide range of end connection types and sizes:

[7.1] Flanges: Plastic or metal "Corona" with elongated slots enable meeting diverse flange standards ISO, ANSI and JIS.

[7.2] Flange adaptor external thread

[7.3] Internal threads

[8] Flange Adapter

Articulated flange connections isolate the valve from line bending and pressure stresses.

[9] Valve Legs

Stabilize the valve and serve also as mounting brackets.

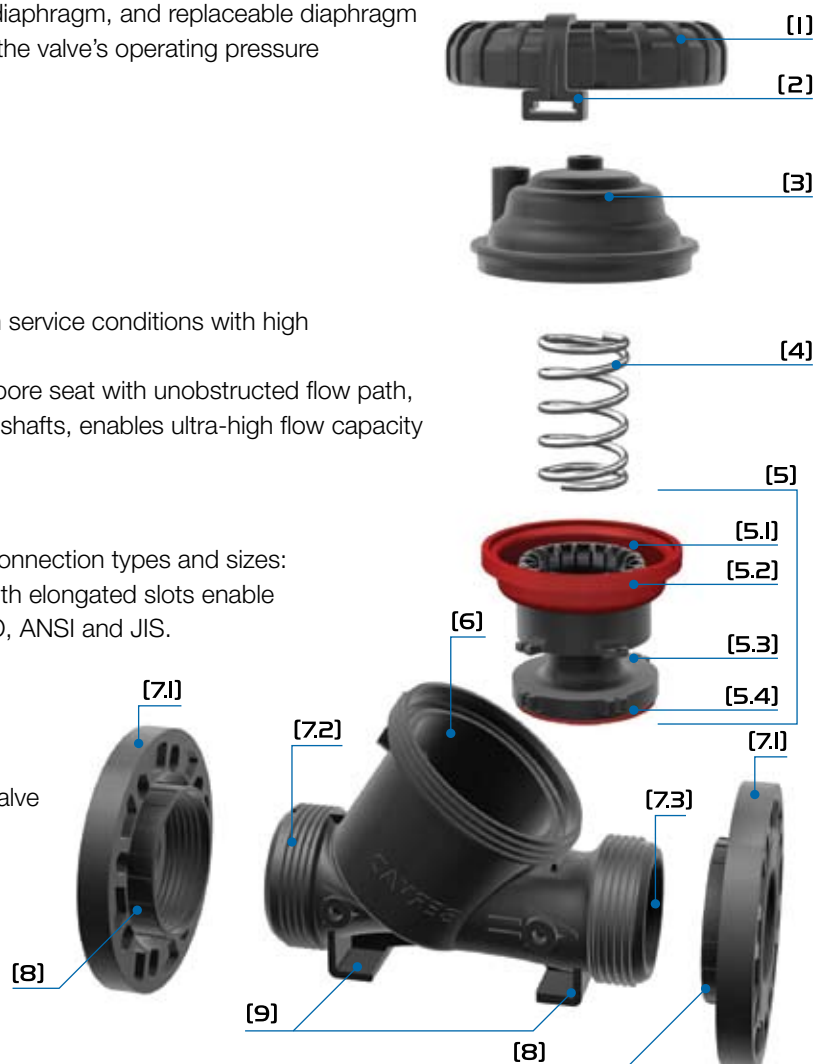

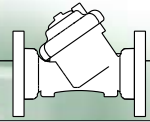

Configuration Options

Valve Configurations

Y Pattern



Available in all sizes

Angle Pattern



Available in 3" & 3"L
DN: 80 & 80L

T Pattern



Available in 3"
DN: 80

Dual T Pattern



Available in 3"
DN: 80

End Connection Options



6"; DN 150 "Boxer" - Flanged



6"; DN 150 "Boxer" - Grooved (Vic)



BSP.T; NPT Female Thread
1 1/2", 2" & 2"L;
DN: 40, 50 & 50L



BSP.F Male Thread,
(for PVC Adaptors)
2", 2 1/2"; DN: 50 & 65



BSP.T; NPT Female Thread
3" & 3"L; DN: 80 & 80L



Union PVC Adaptor
2", 2 1/2"; DN: 50 & 65



Plastic Flange
3"L & 4"; DN: 80, 80L & 100

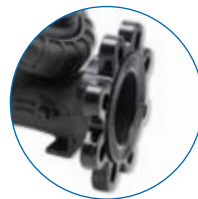

Metal Flange
3"; 3"L & 4";
DN: 80, 80L & 100



PVC Adaptor
1 1/2", 2" & 3"L
DN: 40, 50 & 80L

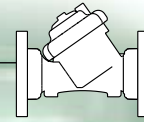

hYflow **Basic Hydraulic Valve, Model 105-Z**

Model 105-Z, is a hydraulically self-operated, diaphragm-actuated valve, which uses the hydraulic force of the existing line pressure, or any external hydraulic command (water or air), to open and close. Recommended for all On\Off applications, Model 105-Z is particularly suitable for agricultural irrigation heads, and filter stations.



hYflow **Electric Valve, Model 110-2W-N**

Model 110-2W-N, is a hydraulically self-operated, diaphragm-actuated, solenoid-controlled valve. The valve opens fully and closes drip-tight in response to an electric signal, which causes the solenoid to open or close the valve's internal hydraulic loop. It operates with a variety of solenoid voltage ranges: 24VAC, 24VDC or 9VDC, 12VDC-latch. Recommended for all electric On\Off applications, Model 110-2W-N is particularly suitable for turf irrigation heads and commercial green house irrigation. The Model 110-2W-N also features a manual override.



hYflow **Pressure Reducing Valve, Model 120-bZ**

Model 120-bZ, is a hydraulically self-operated, diaphragm-actuated control valve, which uses the hydraulic force of the line pressure to reduce higher upstream pressure to lower constant downstream pressure regardless of fluctuating demand or varying upstream pressure. The pilot continuously senses the downstream valve pressure and controls the valve's opening and closing rate accordingly, by increasing or decreasing the flow from the valve control chamber to downstream. The quick and accurate response of Model 120-bZ prevents line fill-up surges and pressure peaks, which can be damaging, especially to thin wall irrigation schemes. The unique hYflow design makes the Model 120-bZ the best and most cost-effective solution for agricultural irrigation heads in large and medium scale blocks, where flow is high and upstream pressure is liable to drop very low.



hYflow **Electric Pressure Reducing Valve, Model 120-55-bZ**

Model 120-55-bZ, is a hydraulically self-operated, diaphragm-actuated control valve which uses the hydraulic force of the line pressure to reduce higher upstream pressure to lower constant downstream pressure, regardless of fluctuating demand or varying upstream pressure. The added solenoid enables the opening and shut-off of the valve by an irrigation controller. Pressure reducing performance of the Model 120-55-bZ is similar to that of the Model 120-bZ, thus providing protection for the irrigation equipment whenever the valve opens and throughout the irrigation cycle. Model 120-55-bZ operates with a variety of solenoid voltage ranges: 24VAC, 24VDC or 9VDC, 12VDC-latch.

Flow Stems on all DN: 40, 50, 50L, 65, 80 and 80L models are available upon request

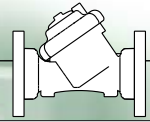

Flow Chart - Metric

100 Series, Control Valves "Y" & Angle Patterns

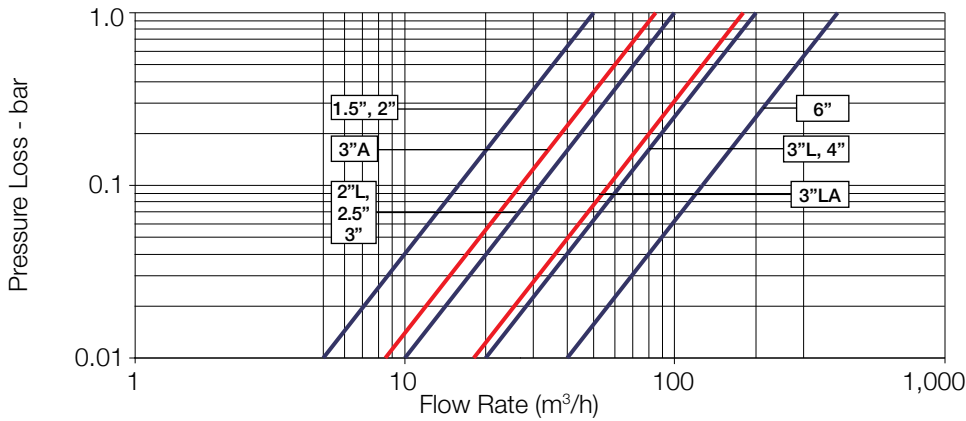

100 Series, Control Valves 3" "T" & Dual Patterns

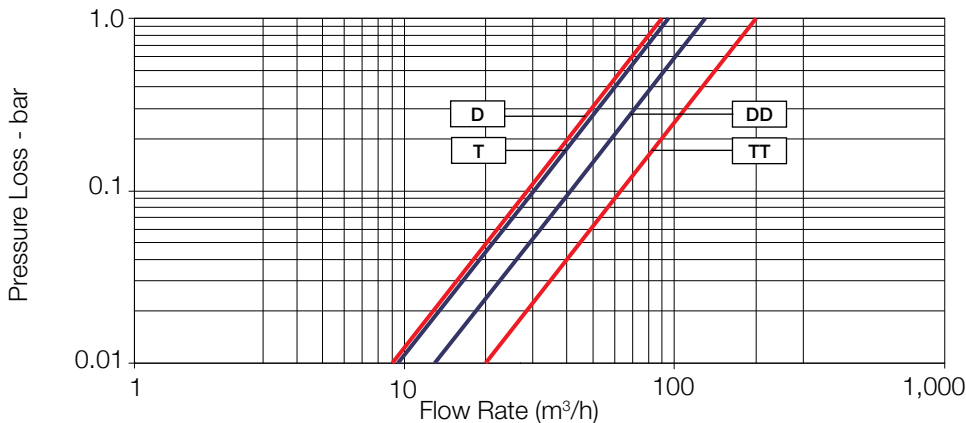

Flow Properties

Sizes DN	40	50	50L	65	80	80	80	80	80	80	80L	80L	100	150
Pattern	Y	Y	Y	Y	Y	A	T	TT	D	DD	Y	A	Y	Y
							One side	Two sides	One side	Two sides				
KV	50	50	100	100	100	85	95	130	90	200	200	190	200	400

Technical Specifications

Available Patterns & Sizes:

DN: 40, 50, 50L, 65, 80, 80L, 100 & 150

Available End Connections:

Threaded: Female BSP-T/NPT DN: 40, 50, 50L, 80 & 80L

Male BSP-F DN: 50, 65

Flanged: DN: 80, 80L, 100 & 150

Plastic or metal "Corona" with elongated slots enable meeting diverse flange standards ISO PN10, ANSI 125, JIS 10K

Pressure Rating: 10 bar

Operating Pressure Range: 0.5-10 bar

Temperature Range: Water up to 60°C

Standard Materials:

- Body, Cover and Plug: Glass-Filled Nylon
- Diaphragm: NBR [Buna-N], Nylon Fabric Reinforced
- Seals: NBR [Buna-N]
- Spring: Stainless Steel
- Cover bolts DN: 40, 50, 50L, 65 & 80

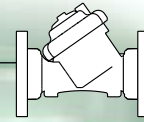

Dimensions & Weights - Metric

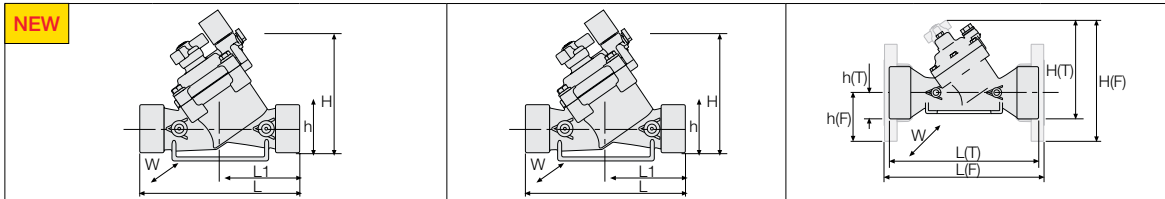

Sizes DN	40	50	50	50L	65	80		
Pattern	Y	Y	Y	Y	Y	Y	Y	Y
Ends Connections	Rc 1 1/2 (BSP.T)	G 2 (BSP.F)	Rc 2 (BSP.T)	Rc 2 (BSP.T)	G 2 1/2 (BSP.F)	Rc 2 (BSP.T)	Universal Flanges	
	1 1/2" NPT	Male	2" NPT	2" NPT	Male	3" NPT	Metal	Plastic
L (mm)	200	200	200	230	230	298	308	308
H (mm)	156	156	156	170	170	180	240	240
h (mm)	40	40	40	40	40	50	100	100
W (mm)	97	97	97	135	135	190	100	100
CCDV (LIT)	0.15	0.15	0.15	0.2	0.2	0.2	0.2	0.2
Weight (Kg)	0.8	0.8	0.8	1.35	1.4	1.6	4.4	2.5

CCDV = Control Chamber Displacement Volume

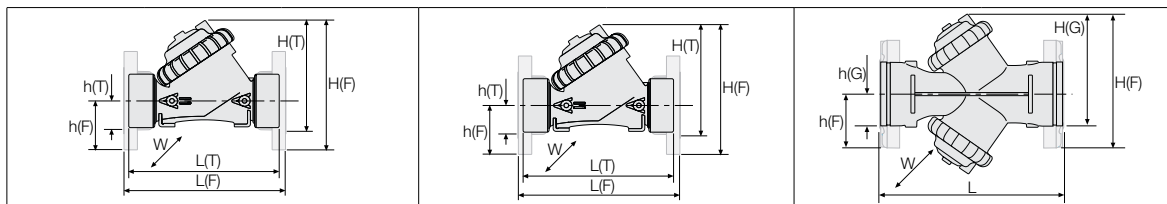

Sizes DN	80 L			100		150	150
Pattern	Y	Y	Y	Y	Y	Y "Boxer"	Y "Boxer"
Ends Connections	Rc 3 (BSP.T)	Universal Flanges		Universal Flanges		Grooved ends	Universal Flanges
	3" NPT	Metal	Plastic	Metal	Plastic	150 (Vic)	150 Plastic
L (mm)	298	310	310	350	350	480	480
H (mm)	240	280	280	294	290	195	285
h (mm)	60	100	100	112	112	100	145
W (mm)	190	100	100	115	115	385	385
CCDV (LIT)	0.7	0.7	0.7	0.7	0.7	2x0.7	2x0.7
Weight (Kg)	3	5.9	4	7.6	4.9	8.8	12.8

CCDV = Control Chamber Displacement Volume *Reinforced Plastic Flanges

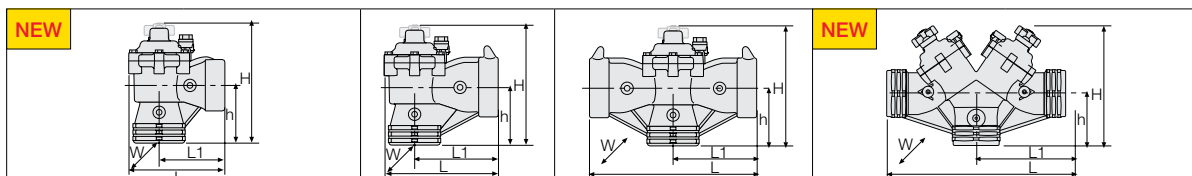

Sizes DN	80L	80	80	80	80	80
Pattern	Angle	Angle	Angle "Horns"	T "Horns"	DUAL "Horns"	DUAL
Ends Connections	Rc 3 (BSP.T)	Rc 3 (BSP.T)	Rc 3 (BSP.T)	Rc 3 (BSP.T)	Rc 3 (BSP.T)	Rc 3 (BSP.T)
	3" NPT	3" NPT	3" NPT	3" NPT	3" NPT	3" NPT
L (mm)	235	187	220	325	400	400
H (mm)	290	235	235	235	270	270
h (mm)	145	117	117	117	115	115
W (mm)	170	135	135	135	135	135
CCDV (LIT)	0.7	0.2	0.2	0.2	2x0.2	2x0.2
Weight (Kg)	2.8	1.6	1.7	2.1	3.2	3.2

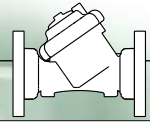

Typical Applications

Irrigation Control Head - Filtration System

Pressure Reducing & Sustaining Separating Valves and quick Pressure Relief Valves



Irrigation Control Head - Filtration System

Pressure Sustaining Separating Valves



Sub-Main Control - Distribution System

Pressure Reducing Valves with Relief Override



Sub-Main Control - Distribution System

Normally Closed Pressure Reducing & Sustaining Main Valve and four Solenoid Controlled Valves



Europe • Asia • Australia • Africa • America

BERMAD Worldwide

With representation on every continent and across some 86 countries, BERMAD is an undisputed world leader in control valves, maintaining broad training and parts distribution networks all over the globe.

Wherever your location, BERMAD is there.

BERMAD International Head Offices:

- BERMAD Australia
- BERMAD Brazil
- BERMAD Chile
- BERMAD China
- BERMAD Colombia
- BERMAD Italy
- BERMAD Mexico
- BERMAD Peru
- BERMAD UK
- BERMAD USA



Irrigation
Hydraulic
Control Valves

info@bermad.com • www.bermad.com

BERMAD Water Control Solutions

BERMAD
Waterworks

BERMAD
Fire Protection

BERMAD
Petroleum

BERMAD
Irrigation

BERMAD
Landscape



info@bermad.com • www.bermad.com

The information herein is subject to change without notice. BERMAD shall not be held liable for any errors. All rights reserved.
© Copyright by BERMAD

PC1AE09

09