



VALVE OPENING SPEED CONTROL DEVICE

Model 02-OSCD

The BERMAD Opening Speed Control Device (OSCD) is a valve control accessory that has an adjustable restricted flow in one flow direction and an unrestricted flow in the opposite direction. The OSCD is designed to be installed on the control trim of BERMAD valves, to reduce the opening speed and thus decrease or eliminate damaging water surge or water hammer. Reduction of the main valve's opening speed is achieved by adjusting the OSCD to restrict the rate of water flow exiting the main valve's control chamber controlling the rate at which the main valve opens. The closing speed remains unaffected as flow in the opposite direction, entering the control chamber to close the main valve remains unrestricted.



Typical Applications

- Fire pump discharge control
- Surge prevention

Technical Data

Pressure Rating: 365 psi

Water Temperature Range: 180 °F

Flow Factor:

Ports inlet to outlet: Cv 0.06 to 0.32

Height (H): 4.1 Inch

Width (W): 1.96 Inch

Ports: NPT 1/2"

Standard Materials:

Body: St. St. 316

Cover: Polycarbonate

Pilot Body: St. St. 316

Elastomers: NBR

Internal Parts: St. St. 316

Optional Materials:

Body: Nickel Aluminum Bronze, Duplex, Hastelloy, Titanium

Cover: Polycarbonate

Elastomers: NBR

Internal Parts: Nickel Aluminum Bronze, Duplex, Hastelloy, Titanium

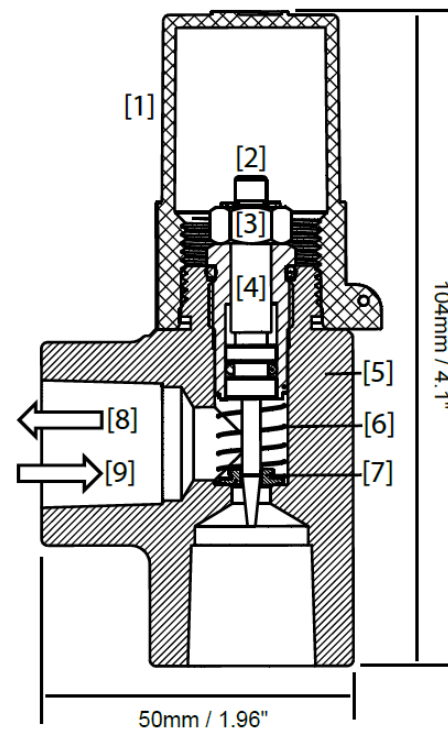

Part	Description
1	Cover
2	Adjusting screw
3	Locking nut
4	Stem
5	Body
6	Spring
7	Non-Return disc
8	Unrestricted flow
9	Restricted flow



02-OSCD

Principle of Operation

The OSCD is typically installed in the control trim of a Bermad main valve to control the opening speed.

When the main valve is closing, the flow direction is in the “unrestricted flow” direction (8) against the spring (6) and the flow control stem (4) the flow causes the non-return disc (7) to leave the seat presenting a relatively unrestricted flow path.

When the flow is reversed to open the main valve, and in the “restricted flow” direction (9) the non return disc is held in place on the seat by the spring force and the flow, presenting an adjustable restricted flow path between the orifice in the non-return disc and the flow control stem.

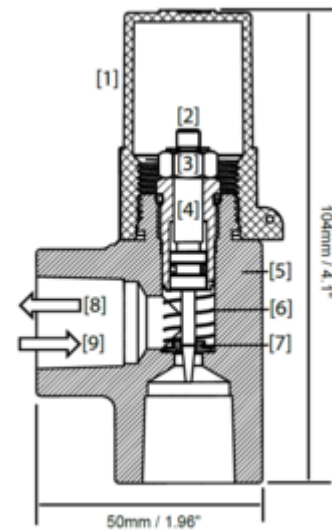

Operation

Unscrew the protective cap (1) and loosen the locknut (3). Turning the adjusting screw (2) clockwise decreases the flow, and will slow the main valve opening. Turning the adjusting screw counter-clockwise increases the flow, and will quicken the main valve opening.

Caution: Adjustment of the CSCD should be strictly restricted to authorized technical personnel only.

Optional Materials

Body	Control Stem	Protective Cap	Seals
St Steel 316 CF8M	AISI 316	Polycarbonate	NBR
Ni Al Bronze ASTM B148	Monel 400	Polycarbonate	NBR
Super Duplex 25Cr	Super Duplex	Polycarbonate	NBR
Titanium Gr.2	Titanium	Polycarbonate	NBR

