

# ALTITUDE LEVEL CONTROL VALVE

## Model FP-450-82

The BERMAD FP 450-82 Level Control Valve is a hydraulically controlled, diaphragm actuated automatic control valve that shuts at a pre-set high reservoir level and opens in response to level drop keeping the reservoir full.

The water level is maintained by the use of a highly accurate pilot valve on the main valve. The pilot valve senses the water level head from a sensing point at the bottom of the reservoir and controls the main filling valve accordingly. This eliminates the need for the installation of a float mechanism, whilst enabling the location of the main valve location to be at floor level and easily accessible, making it ideal for high level reservoirs.



### Features & Benefits

- Safety and reliability
  - Time proven, simple design with a fail safe actuation
  - Single piece rugged elastomer, VRSD technology
  - Obstacle-free, uninterrupted flow path
  - Main valve with no mechanical moving parts
  - Valve position limit switches (optional)
  - Very low opening & closing pressure requirement
  - Quiet and Smooth operation
- High performance
  - Very high flow efficiency
  - High discharge capacity
- Quick and easy maintenance
  - In-line serviceable
  - Fast and easy cover removal
  - External installation for easy access

### Typical Applications

- Elevated Reservoirs - See height codes in Code Designations on last page

### Optional Features

- Large control filter
- Valve position limit switches
- Corrosion resistant zinc based high build epoxy coating

### Operation

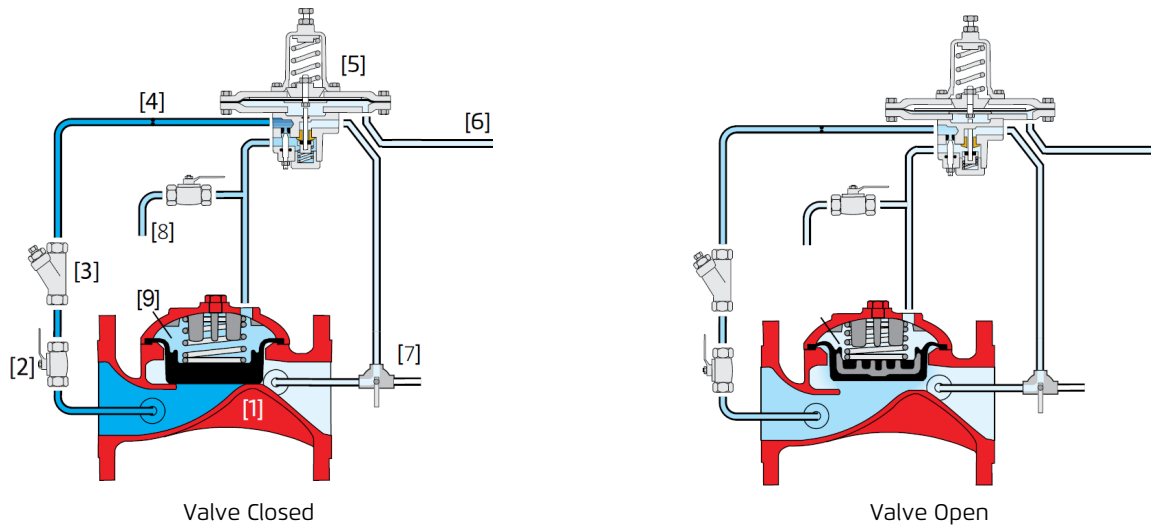

The Model FP 450-82 is a pilot controlled valve equipped with an adjustable #82 altitude pilot valve[5]. The pilot valve senses the static head of the reservoir level via a sensing tube [6] connected to a “still point” at the bottom of the reservoir. Should the water level head rise to that equaling the setting of the pilot valve [5] the pilot valve will close, thereby allowing valve inlet water pressure to accumulate in the main valve control chamber [9] via the fixed orifice [4], causing the main valve to close drip tight.

Should the Water Level head fall below the pilot valve setting, the pilot valve will open releasing pressure from the main valve control chamber, causing it to open and to fill the reservoir.

As the water level in the reservoir approaches the pre-set full level the pilot starts to modulate causing the main valve to throttle in a controlled manner and close drip tight.

The restriction orifice [4] ensures a smooth operation of the main valve by regulating the closing speed.

The emergency valve [8] enables a manual override opening of the main valve.

### System P&ID

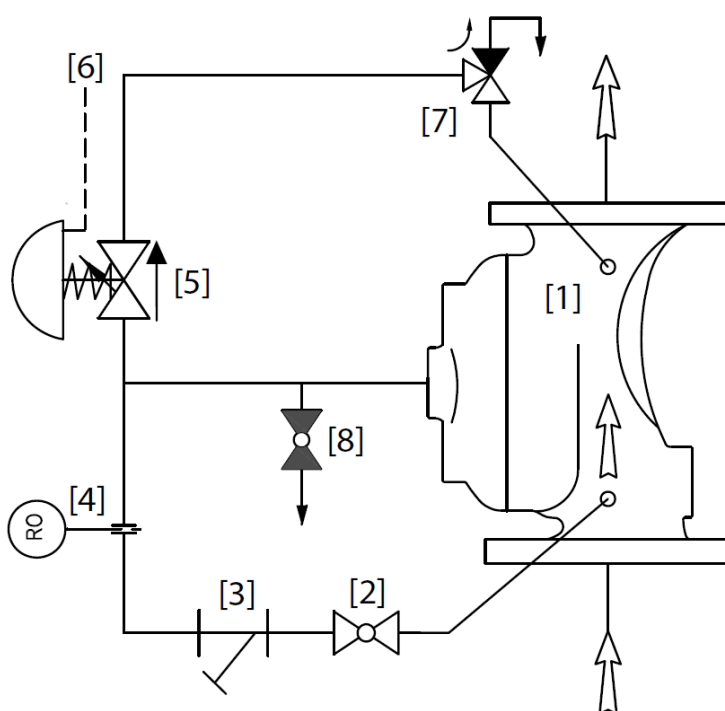

Components	
1	BERMAD 400 Valve
2	Priming Ball Valve
3	Priming Strainer
4	Restriction Orifice
5	Altitude Pilot Valve 82
6	Reservoir Water Level Sensing Line
7	Test Valve
8	Emergency Release Valve

## System Installation

The Model FP 450-82 senses the static head of the water level in the tank by means of a high sensitivity altitude pilot valve. To do so accurately, the sensing tube end must be connected to a "still point" at the bottom of the tank. The drainage pipe provides this "still point", a location not influenced by flow velocity from the filling and outflow pipes.

In firewater reservoirs, the water level should be kept as constant as possible, with a highly accurate altitude pilot valve the Model FP 450-82 is well suited to fulfill this requirement.

The altitude pilot is highly sensitive to changes and accurately maintains the reservoir water level at no more than approximately 30cm or 1ft below the set level.

### High Elevated Water Tower

- The Model FP 450-82 senses the static head of the water level in the tank by means of a high sensitivity altitude pilot valve. To do so accurately, the sensing tube end must be connected to a "still point" at the bottom of the tank. In many cases the drainage pipe provides this "still point"

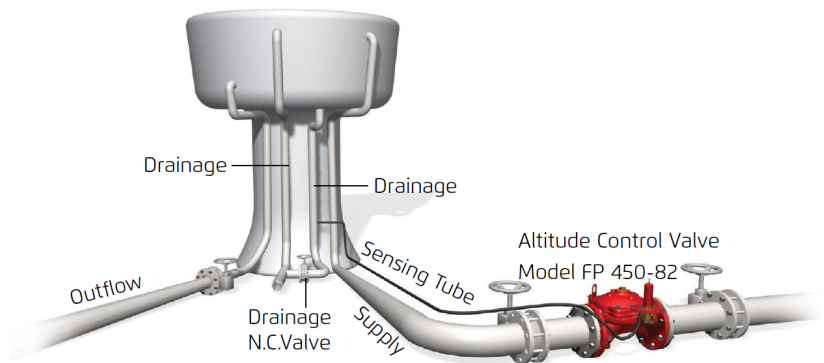

### Large Fire Water Reservoirs

- The altitude pilot is highly sensitive to changes and accurately maintains the reservoir water level at no more than approximately 30cm or 1ft below the set level.



## Suggested Specifications

The Level Control Valve shall shut at pre-set high reservoir level and open in response to a level drop, as sensed by the #82 high sensitivity altitude pilot valve mounted on the main valve.

**Main Valve:** The main valve shall be an elastomeric globe type valve with a rolling-diaphragm. The valve shall have an unobstructed flow path, with no stem guide or supporting ribs. The body and cover construction material shall be ductile iron. All external bolts and nuts shall be of Stainless Steel 316. All valve components shall be accessible and serviceable without removing the valve from the pipeline.

**Actuation:** Valve actuation shall be accomplished by a fully peripherally supported, single-piece balanced rolling-diaphragm, vulcanized with a rugged radial seal disk. The diaphragm assembly shall be the only moving part.

**Control System:** The control system shall consist of a #82, altitude pilot valve with a covered, centered spring and 8" (200 mm) sensing diaphragm, an isolating ball valve, Y control filter. All fittings shall be of stainless steel 316. The assembled valve shall be hydraulically tested.

**Quality Assurance:** The valve manufacturer shall be certified according to the ISO 9000 and 9001 Quality Assurance Standard.

## Technical Data

### Available Sizes:

Flanged- 1½, 2, 2½, 3, 4, 6, 8, 10 & 12"

Grooved- 2, 3, 4, 6, & 8"

### Pressure Rating:

ANSI#150 - 17.2 bar | 250 psi

Grooved - 17.2 bar | 250 psi

### Elastomer:

HTNR - Fabric Reinforced High Temperature

Compound - See [engineering](#) data

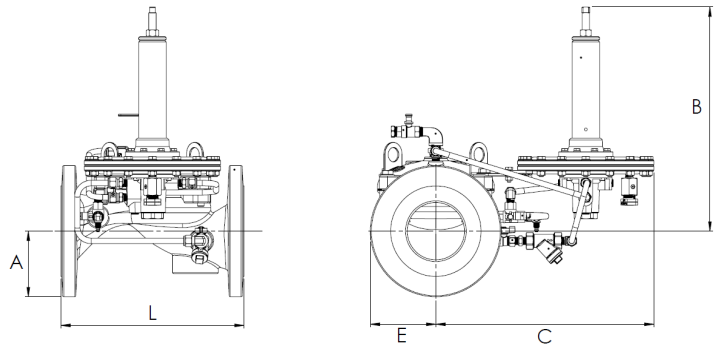

Valve Size	L #150 mm   in	L Grooved mm   in	L #300 mm   in	A mm   in	B mm   in	C mm   in	∅D in	E mm   in	F mm   in	G mm   in	Weight #150 kg   lb
DN40   1½"	205   8.1	-	-	78   3	348   13.7	331   13	-	78   3	-	-	17   38
DN50   2"	205   8.1	205   8.1	-	78   3	348   13.7	331   13	-	78   3	-	-	18   40
DN65   2½"	205   8.1	-	-	-	-	-	-	-	-	-	20   44
DN80   3"	257   10.1	250   9.8	-	100   3.9	373   14.7	353   13.9	-	100   3.9	-	-	29   63.8
DN100   4"	320   12.6	320   12.6	-	115   4.5	391   15.4	372   14.6	-	112   4.4	-	-	41   90
DN150   6"	415   16.3	415   16.3	-	140   5.5	444   17.5	437   17.2	-	153   6	-	-	85   187
DN200   8"	500   19.7	-	-	172   6.8	488   19.2	464   18.3	-	183   7.2	-	-	148   326
DN250   10"	605   23.8	-	-	488   19.2	386   15.2	464   18.3	-	203   8	-	-	164   361
DN300   12"	725   28.5	-	-	242   9.5	531   20.9	500   19.7	-	305   12	-	-	251   552

**IMPORTANT:** Dimensions for the trim envelope or extents refer to a vertical orientation and may vary with specific component positioning - Apart from the "L" dimension, allow a tolerance of at least ±15%

## Valve Code Designations

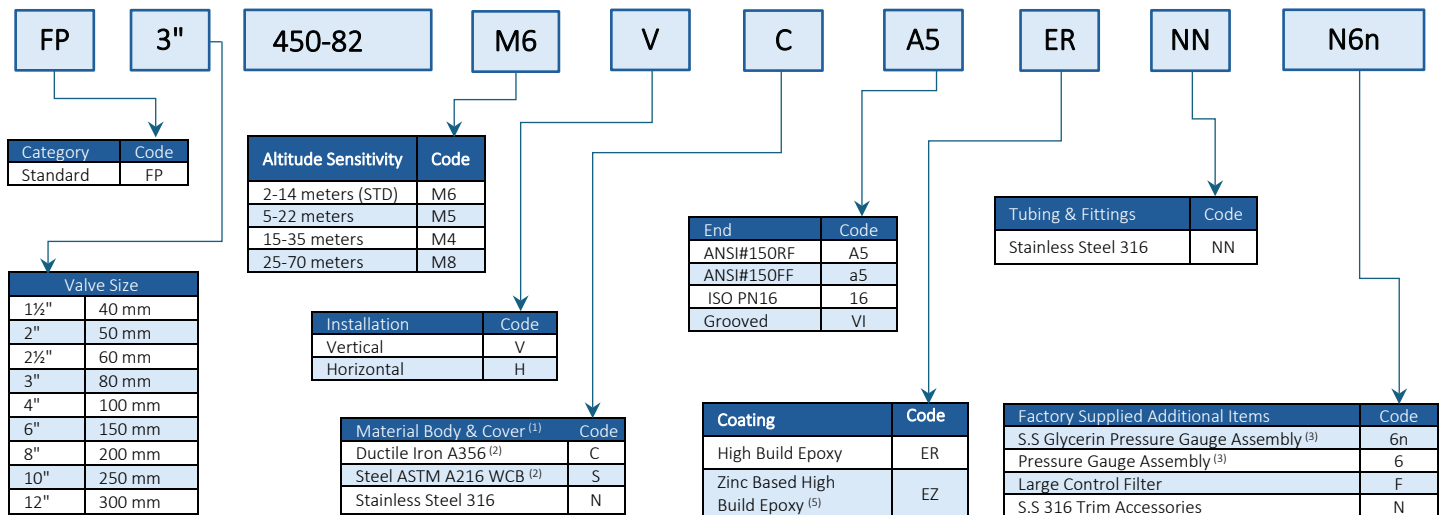

(1) Other materials available see engineering data  
 (2) Coated internally and externally  
 (3) Supplied loose  
 (4) Consult BERMAD for availability  
 (5) For valves up to and including 10"

\*More options available – consult BERMAD