

BERMAD Meters

Electromagnetic flowmeters



MC608 CONVERTER

User and
maintenance manual





This document must be delivered to the user before machine installation and commissioning.

Symbols used in this manual

In order to draw the attention of all personnel working with the equipment supplied by BERMAD, the points of particular importance described in this manual are highlighted with graphic signs and different colors that will make them easily identifiable.

Legend



CAUTION! This sign indicates a risk of electric shock! All operations marked with this sign must be performed exclusively by qualified technical personnel.



CAUTION/WARNING: This symbol indicates vital information and points to be observed. Please refer to the related documents.



NOTE: This symbol indicates information and points of particular importance to be observed.

READ THE INSTRUCTIONS CAREFULLY AND KEEP THEM IN A SAFE PLACE

This manual can be downloaded from the website www.bermad.com in the Area Download section. We want you to save time and money!

We assure you that, having read this manual thoroughly, you will be able to perform correct installation and fully use the product in total safety.

1	INTRODUCTION	5
1.1	MANUFACTURER'S STATEMENT	5
1.2	PACKAGING VERIFICATION	5
1.3	PRELIMINARY NOTES	6
1.4	PRODUCT IDENTIFICATION	6
1.5	APPLICATIONS	7
2	PRODUCT DESCRIPTION	8
2.1	OPERATING PRINCIPLE	8
2.2	AVAILABLE VERSIONS	8
2.3	CONVERTER INSTALLATION TYPES	10
2.4	CASING	10
2.5	POWER BATTERIES	10
2.6	DATA SAFETY	11
2.7	REMOTE DATA READING	12
2.8	OPTIONAL MODULES	12
2.8.1	Hart protocol available for MC608A	12
2.8.2	Optional module Pressure/Temperature for MC608A	12
3	TECHNICAL SPECIFICATIONS	13
3.1	OVERALL DIMENSION	13
3.1.1	Version MC608A (COMPACT)	13
3.1.2	Version MC608B/R (COMPACT)	13
3.1.3	Version MC608A (REMOTE)	13
3.1.4	Version MC608B/R (REMOTE)	14
3.1.5	Version MC608P (REMOTE)	14
3.1.6	Version MC608I (REMOTE)	14
3.2	CERTIFICATES AND APPROVALS	15
3.3	GENERAL TECHNICAL FEATURES	16
3.4	ACCURACY	18
3.4.1	Reference conditions	18

4	INSTALLATION	20
4.1	MOVING	20
4.2	CONVERTER POSITIONING	21
4.2.1	Positioning/installation of the converter in COMPACT version	21
4.2.2	Positioning/installation of the converter in REMOTE version	22
4.2.3	Relation between conductivity and cable length	23
4.2.4	Installation of the solar panel on MC608R in the COMPACT version	24
4.3	ELECTRICAL CONNECTION	25
4.3.1	Wiring diagram	25
4.3.2	Connection to the sensor	27
4.3.3	Connection options I/O	27
4.3.3.1	Pulse output	27
4.3.3.2	Programmable output	28
4.3.3.3	Output 4...20mA	29
4.3.3.4	MODBUS RS485 interface	29
4.3.4	Electrical grounding of the converter	30
4.3.5	Connection to the power supply	31
5	MC608 CONVERTER PROGRAMMING	32
5.1	CONVERTER CONFIGURATION METHODS	32
5.1.1	Software MC608 configuration	32
5.1.2	Converter Password	33
5.2	PROGRAMMING	34
5.2.1	Data display description	35
5.2.2	Status icons identification and description	36
5.2.3	Device programming/configuration menu	36
5.3	MENU ITEMS DESCRIPTION	39
5.3.1	MENU → PREFERENCES	39
5.3.2	MENU → COUNTERS	41
5.3.3	MENU → PARAMETERS	42
5.3.4	MENU → I/O	44
5.3.5	MENU → OTHER	46
5.3.6	MENU → MEMORY	47
6	MAINTENANCE	49
6.1	CABLE GLAND CLOSING AND GASKET CONDITION CHECK	49
6.2	BATTERY INSTALLATION/REPLACEMENT ON MC608B/R	49
7	TROUBLESHOOTING	51
7.1	MALFUNCTIONING AND POSSIBLE SOLUTIONS	51
7.2	ALARM MESSAGES SOLUTION	53
8	SENDING THE CONVERTER (COMPACT VERSION) TO THE MANUFACTURER	54
8.1	REPAIR REQUEST FORM	54
9	PRODUCT DISPOSAL	55

1 INTRODUCTION



IMPORTANT WARNING! It is very important that all personnel working with the equipment have read and understood the instructions and indications provided in this manual, and that they follow them prior to using the equipment itself. The manufacturer assumes no responsibility for the consequences resulting from improper use by the worker.

The suitability of the device for particular purposes shall be worker's responsibility.

The warranty will be considered void in case of improper installation and use of devices (systems).

- The manufacturer shall bear no responsibility for any damage caused by improper use, improper installation or tampering of own products. Installation, connection, commissioning and maintenance must be carried out by personnel who are qualified and authorized for this purpose. The personnel in charge of the installation must make sure that the measurement system is properly connected as per the wiring diagram indicated in this document.
- The manufacturer shall bear no responsibility for any damages or injuries resulting from any misunderstanding of this manual. In order to avoid possible accidents to persons or things caused by incorrect interpretation of the instructions, the user must not proceed with operations and/or interventions on the converter if there are uncertainties or doubts regarding the operation(s) to be performed. We recommend contacting Assistance Service for clarifications in this regard for more precise instructions.
- The manufacturer will be held responsible only if the converter will be used in its original configuration.

For applications that require high working pressures or use of substances that may be dangerous for people, the environment, equipment or anything else: In case of pipe breakage, BERMAD recommends to take the necessary precautions such as adequate positioning, protection or installation of a guard or safety valve, before installing the CONVERTER in the COMPACT version.

The device contains live electrical components, therefore installation, checks and maintenance must be carried out by experienced and qualified personnel who are aware of all necessary precautions to be taken. Before opening any internal part, please disconnect the power supply.

1.1 MANUFACTURER'S STATEMENT

- Stresses and loads possibly caused by earthquakes, strong winds, fire damage, vibrations and natural disasters were not taken into account in the phase of machine designing.
- Do not install the machine in such a way that it acts as a focus for stresses on the pipes. External
- loads were not taken into account in the device configuration.
- While the device is working, the pressure, supply voltage and/or temperature values indicated on the label or in this Operating Manual must not be exceeded.

1.2 PACKAGING VERIFICATION

At the moment of purchase and/or upon receipt of the product, the buyer is strongly advised to check the quality of the packaging which must be intact, without visible dents and completely and correctly closed.

When opening the packaging, also check that the product complies with the information on the packing list in terms of completeness of components/accessories.



NOTE: All BERMAD software packages are available on the USB flash drive key that accompanies the product. The software can also be downloaded from the website www.bermad.com by accessing the Download Area. A free registration will be required after which you can download the configuration software for your product.

1.3 PRELIMINARY NOTES

Main parts of the electromagnetic flowmeter are:

- **Sensor** – installed in the tube with the use of flanges and other joints;
- **Converter** – can be installed on the sensor (in compact version) or remotely (in remote version) connected with two pipes.

Electromagnetic flowmeters have many important advantages compared to their mechanical counterparts, such as: exceptional long-term stability, maximum process reliability and zero maintenance. As a result, these sensors can provide accurate and reliable long-term measurements.

See the following paragraphs for more detailed information on correct installation.



NOTES:

Electromagnetic flowmeters are designed specifically to operate under the following basic conditions:

1. The liquid must be conductive
2. The tube must always be completely full
3. The input and output distances must be on recommended settings
4. The grounding instructions must be followed

1.4 PRODUCT IDENTIFICATION

Each **MC608** Converter manufactured by BERMAD has a STANDARD identification plate (Fig. 1) or OIML (Fig. 2), that displays the following information:

STANDARD PLATE

- **CE conformity mark.**
- **MODEL:** converter model.
- **IP:** converter protection class.
- **S/N:** serial number which identifies the device.
- **TEMP:** minimum/maximum temperature of the working conditions.
- **POWER S.:** power supply or battery voltage (MC608B).
- **Hz:** power supply frequency.
- **COUPLING:** serial number which identifies the sensor connected to the converter.
- **OPTIONAL:** other modules can be added.



- This symbol means that the product must be disposed of according to the legal requirements.

BERMAD		CE Made in Italy	
MODEL	MC 608A	IP	68
S/N	LCA0448	TEMP	-20 + 60 C
POWER S.	100/240 V	Hz	50/60
COUPLING	LBG0438		
OPTIONAL			

Fig. 1 STANDARD Identification Plate

OIML PLATE:

- **CE conformity mark**
- **MUT2200EL/...:** sensor/converter model.
- **S/N:** sensor/converter serial number.
- **Y:** production year.
- **Size:** diameter of the flange.
- **Q3:** permanent flow rate and ratio.
- **Supply:** voltage and frequency.
- **R49/2013...:** reference certificate.
- **MAP:** maximum allowable pressure.
- **Press Loss Class:** pressure loss class.
- **Env. Class:** environmental class.
- **EMC Class:** EMC class.
- **Inst. Sensitivity:** installation sensitivity class



- This symbol means that the product must be disposed of in accordance with the legal requirements.



		Via Della Tecnica, 20 35035 Mestrino (PD) - Italy Made in Italy		
MUT2200EL / MC608		R49/2013-CZ-16.01		CE
S/N	FSC4552 / RSF4456	MAP	16bar	
Y	2018	Press. Loss Class	Δp10	
Size	DN50 EN1092-1 / PN16	Env. Class	B	
Q3	25m³/h R63	EMC Class	E2	
Supply	90-260V - 50Hz	Inst. Sensitivity	U5/D3	

Fig. 2 OIML



The identification plate must never be removed, damaged or changed. It must also be kept clean from any dirt deposits, as the data contained are the only safe and unambiguous way to recognize the type of converter and be able to complete the repair request form attached to this manual.

1.5 APPLICATIONS

MC608 is widely used for purposes in which it is important to measure the flow rate of electrically conductive liquids. Examples of typical applications for the MC608 converter are:

- Extraction and distribution points
- District-level measures
- Irrigation
- Wastewater treatment systems
- Leak detection systems
- Remote applications without access to electrical grid

2 PRODUCT DESCRIPTION

2.1 OPERATING PRINCIPLE

MC608 converter has been designed with the aim of fulfillment of all the requirements of modern water management systems, through a flexible and hybrid electronics which, depending on the model, offers various power supply solutions.

An electromotive force is induced at the ends of a conducting fluid that moves with velocity v in a magnetic induction field B and can be expressed as:

$$e = kBDv$$

Where it is:

B is constant by construction;

D is constant and represents the distance between the electrodes **E1** and **E2** (equivalent to the diameter of the flowmeter);

v is the fluid velocity;

k is the calibration constant;

emf «e» is proportional to the velocity «v»

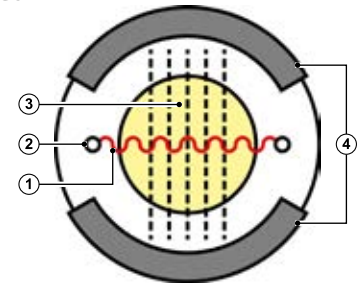

- 1- Electromotive force (proportional to the velocity);
- 2 - Electrodes;
- 3 - Magnetic field;
- 4 - Coils;

2.2 AVAILABLE VERSIONS

The MC608 converter is available in 5 versions, and can cover all the different types of applications depending on the category of system to be monitored.

Specifically, BERMAD produces the converter in the following versions:

MC608A

Power 12/24 Vac-dc or 90/264 Vac.
Aluminium casing.



MC608B

Battery powered with useful life up to 10 years
(maximum diameter DN600 with integrated flow meters).
Aluminium casing.

MC608R

Rechargeable battery powered, with solar panel
(maximum diameter DN600 with integrated flow meters).
Aluminium casing.

MC608P

Power at 12/24 Vac-dc.
Version with a panel.
Polycarbonate casing.

MC608I

Power at 12/24 Vac-dc o 90/264 Vac with internal
back-up battery or rechargeable battery with solar panel.
Stainless steel casing.

2.3 CONVERTER INSTALLATION TYPES

Depending on the version of the MC608 converter, it can be installed in the system in two different ways:



Fig. 3 Compact Version

COMPACT (Fig. 3): The converter is mounted to the relevant detection sensor.



Fig. 4 Remote version

REMOTE (Fig. 4): The converter, if powered from the mains (MC608A/P/I) can be installed up to 100 meters away from the sensor while battery-powered converter (MC608B/R) can be installed up to a maximum of 30 meters away from the sensor.

2.4 CASING

The MC608 converter is protected by suitable casing specifically chosen for each product version. In particular, protective casings can be:

- Solid and reliable casing in aluminium IP68 for MC608A/B/R
- Stainless steel IP54 casing for MC608I for remote installations
- Solid thermoplastic casing for installations in electrical cabinets MC608P

2.5 POWER BATTERIES

The MC608B and MC608R converters are battery-powered via a primary lithium battery as well as a rechargeable lithium battery. It is therefore necessary to consider the following:

- Lithium batteries are the primary energy source because of their high-energy density, and are created to meet the highest safety standards. However, they can be potentially hazardous if they are exposed to electrical or mechanical abuse. In many cases, this is associated with excessive heat production in which the increased internal pressure could lead to cell rupture.

These basic precautions need to be followed when handling and using lithium batteries:



IMPORTANT INSTRUCTIONS!

- Do not short-circuit, recharge, overload or reverse-connect the battery
- Do not expose the battery to temperatures higher than those specified, as it will incinerate
- Do not crush, puncture or open the cells or disassemble the battery packs
- Do not weld or braze the battery body or battery packs
- Do not expose the contents to water

The use of lithium batteries is regulated under the United Nations Model Regulations on the Transport of Dangerous Goods (UN Model Regulations on the Transport of Dangerous Goods), document ST/SG/ AC.10/1 Rev. 20.

These are basic precautions that should be followed during the transport of lithium batteries:



IMPORTANT NOTES!

- Transport only in special packages with labels and special transport documents specific to current regulations.
- Be careful when handling, transporting and packing the batteries so as to avoid short-circuiting.
- The batteries comply with the requirements set out in the "UN Manual of Tests and Criteria, Part III, subsection 38.3" for air transport and with the provisions of the ADR regulations for transport by truck/ship.



Remove the battery from the transmitter before sending the flow meter to BERMAD in case of maintenance or any intervention under warranty.

2.6 DATA SAFETY



All versions of the MC608 converter guarantee safety of the collected and processed data as a result of the internal memory (EEPROM) on which the data are saved.

The integrated circulating memory allows the storage of data with 200,000 log lines (the data are kept for more than 6 years with factory settings); when the memory is full, the new data will automatically overwrite the old data.

In order to prevent the loss of saved data, and to be able to better manage it on its management systems, the unit is supplied with a specialized software that allows users to communicate with the electronics of the MC608 via IrCOM or RS485 Modbus serial interfaces, that can be connected to any PC, laptop and/or tablet with a Windows operating system.

Fast download, data management, easy programming and an advanced self-diagnosis system, that automatically perform a wide range of essential checks, make the MC608 converter a highly efficient and irreplaceable tool for fluid detection in water management systems.

A multi-level password system also allows controlled access to the data collected and guarantees confidentiality.

2.7 REMOTE DATA READING

The GSM module allows data collection on site and remote monitoring via the GSM/GPRS network and allows any client to access all the information easily and without any cost. An additional communication module automatically sends the information via SMS, e-mail (with or without attachment) and to the free access site www.bermad.com, using any browser and entering personal ID and password. This option is available also on smartphones and tablets.

For more information on the GSM module, refer to document TD 211.

2.8 OPTIONAL MODULES

2.8.1 Hart protocol available for MC608A.

The MC608A/I converter can be equipped with an optional module (installable only by the manufacturer) which acquires the Hart connectivity on the 4-20mA output, granting the access to all quantities measured by the device as well as to the operating parameters. A MC608 converter equipped with Hart connectivity has no Modbus connectivity on RS485.

For more information on Hart, refer to the relevant documentation.

2.8.2 Optional module Pression/Temperature for MC608A.

All the versions of the MC608 converter can be equipped with an optional module (installable only by manufacturer) to which one or two wired probes are connected that allow the device to measure the pressure and temperature of the process. This information, in addition to being stored in the internal data logger, can be directly viewed on the display (Para.5.2.1, p.34), is accessible via Modbus / Hart and is transmitted by the GSM module (if installed) in the manner laid out by the same device.

3 TECHNICAL SPECIFICATIONS

3.1 OVERALL DIMENSION

The overall dimensions of single versions of the MC608 converters are shown below.

3.1.1 Version MC608A (COMPACT)

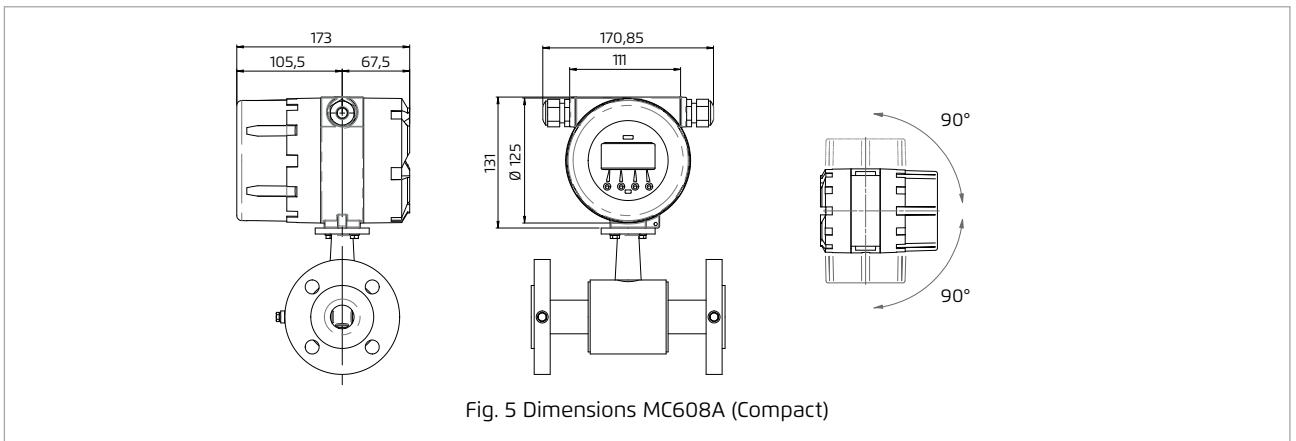

Fig. 5 Dimensions MC608A (Compact)

3.1.2 Version MC608B/R (COMPACT)

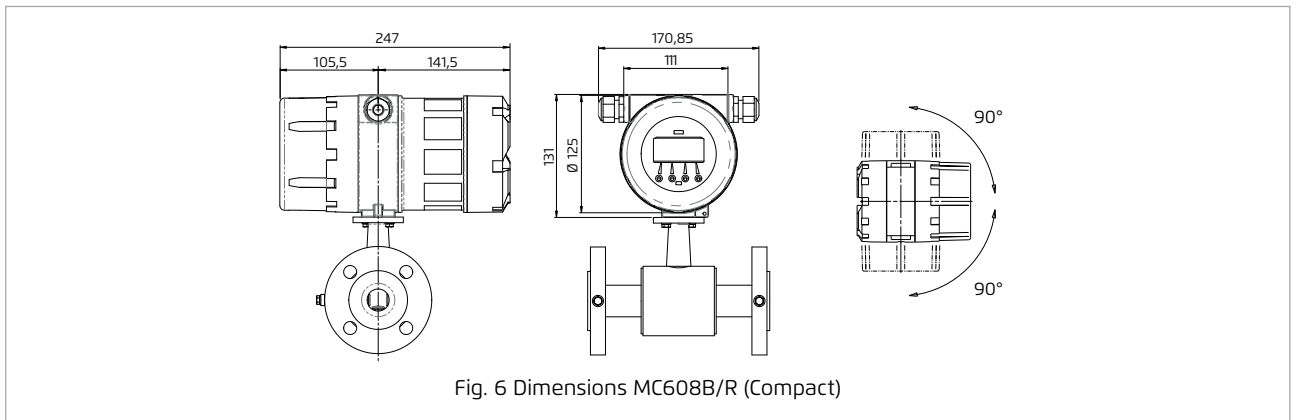

Fig. 6 Dimensions MC608B/R (Compact)

3.1.3 Version MC608A (REMOTE)

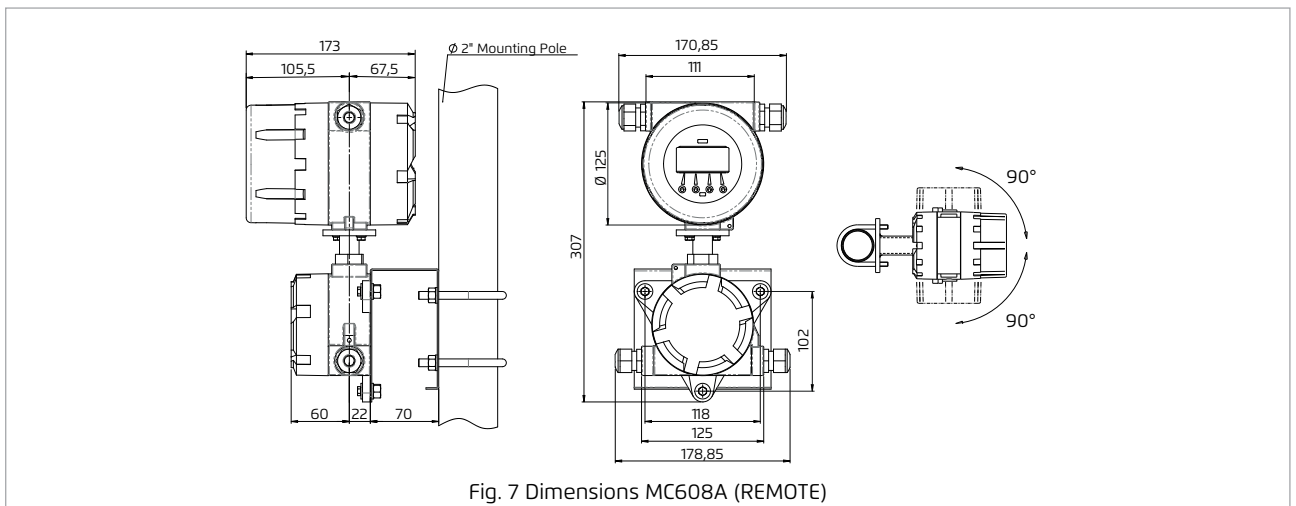
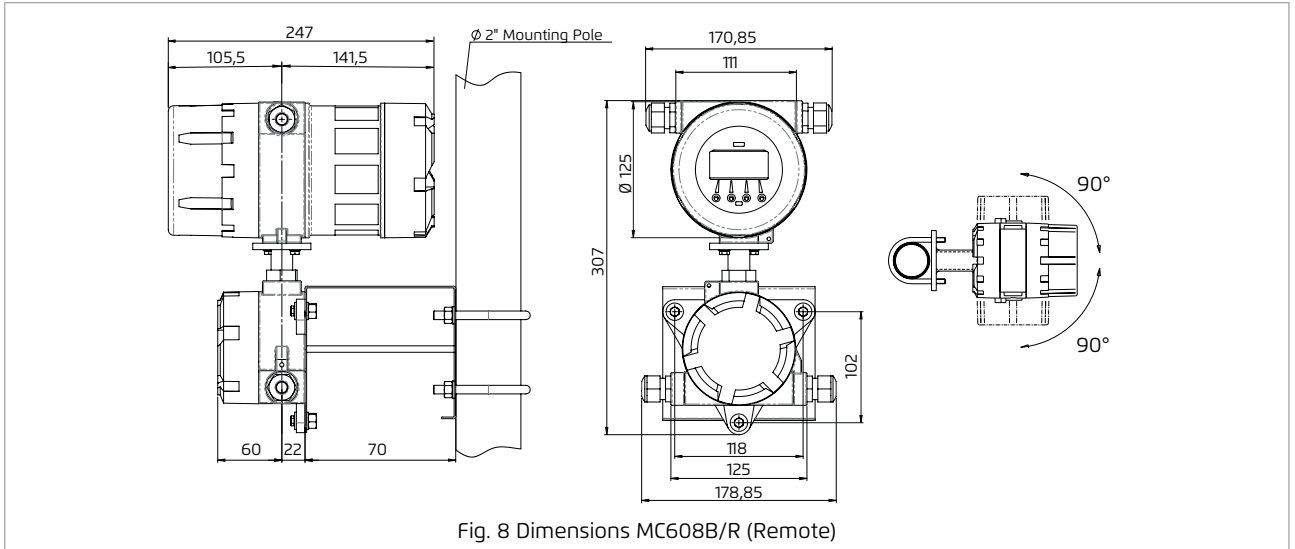
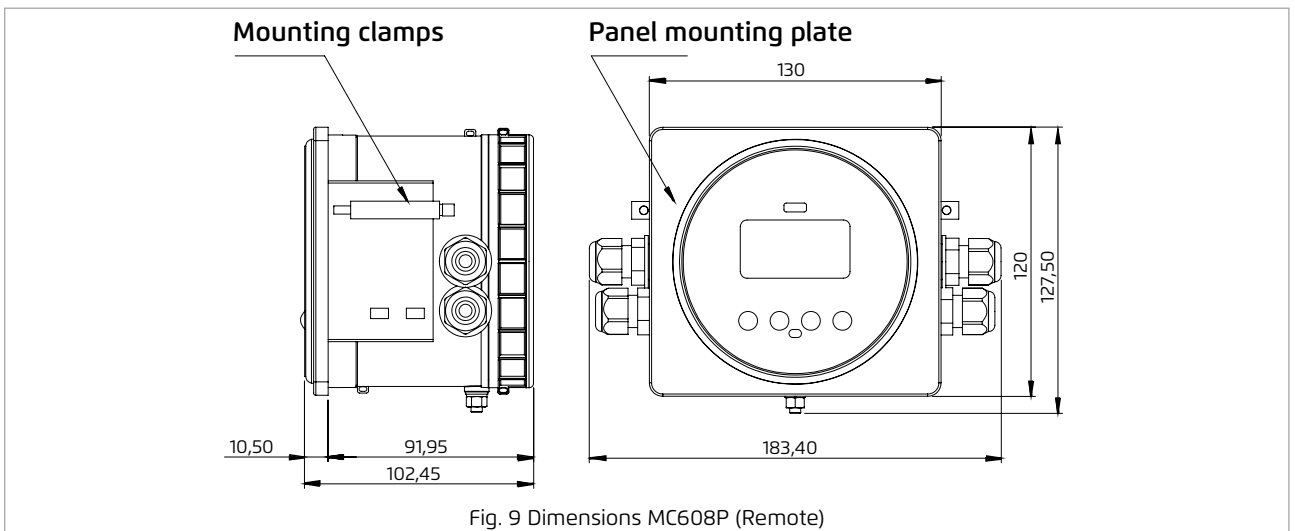

Fig. 7 Dimensions MC608A (REMOTE)

3.1.4 Version MC608B/R (REMOTE)



3.1.5 Version MC608P (REMOTE)



3.1.6 Version MC608I (REMOTE)

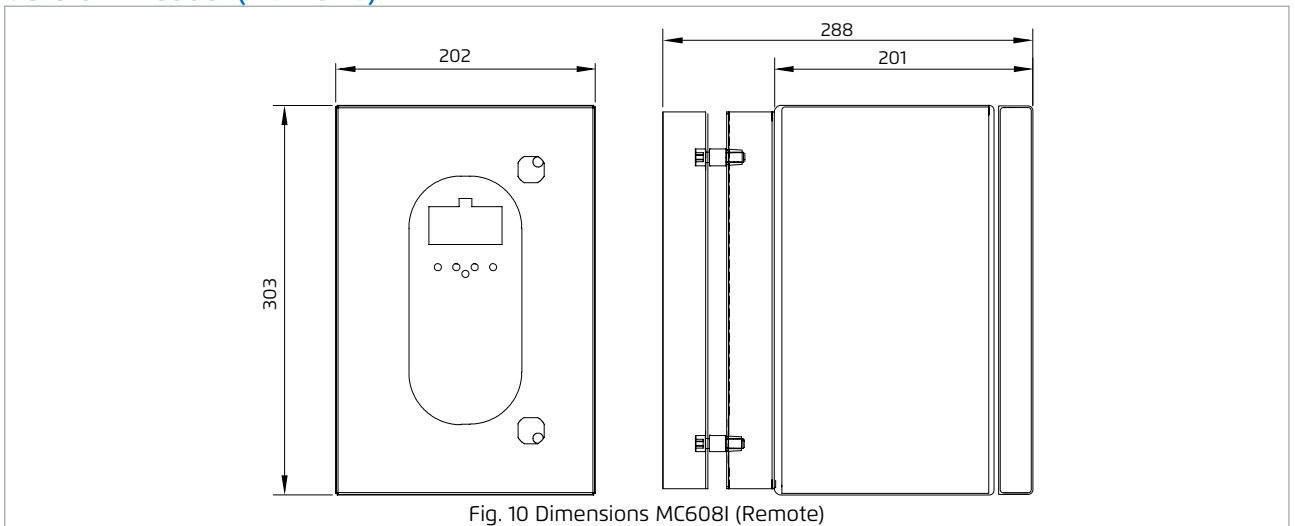

3.2 CERTIFICATES AND APPROVALS

<p style="text-align: center;">MARKING</p> 	<p>The device, connected to the relevant sensor, complies with the requirements of the applicable EU directives. These are listed together with the applied standards in the relevant EU Declaration of Conformity.</p>		
	<p>Electromagnetic compatibility Directive 2014/30/UE</p>		
	<p>Harmonised standards:</p>	<p>For all the versions</p>	<p>EN 61326-1</p>
			<p>EN 55011</p>
			<p>EN 61000-3-3</p>
			<p>EN 61000-4-2</p>
			<p>EN 61000-4-3</p>
			<p>EN 61000-4-4</p>
			<p>EN 61000-4-5</p>
			<p>EN 61000-4-6</p>
<p>EN 61000-4-8</p>			
<p>EN 61000-4-11</p>			
	<p>For GSM versions</p>	<p>ETSI EN 301 489-1</p>	
		<p>ETSI EN 301 489-7</p>	
		<p>ETSI EN 301 489-17</p>	
		<p>ETSI EN 301 489-24</p>	
		<p>EN 55022</p>	
		<p>EN 61000-3-2</p>	
		<p>ETSI EN 301 511</p>	
		<p>ETSI EN 301 908-1</p>	
		<p>ETSI EN 301 908-2</p>	
		<p>Electrical safety Directive 2014/35/EU</p>	
<p>Harmonised standards:</p>	<p>For the versions without GSM:</p>	<p>EN 61010-1</p>	
	<p>For GSM versions:</p>	<p>EN 60950-1</p>	
<p>RoHS Directive 2011/65/UE</p>			
<p>Certificates and international standards</p>	<p>ISO 20456: Measurement of fluid flow in closed conduits IEC 60529: Degrees of protection provided by enclosures (IP Code) HART: HART 7 Protocol OIML R49: Water meters intended for the metering of cold potable water NMI M 10: Meters Intended for the Metering of Water in Full Flowing Pipes</p>		
<p>Sensor certifications</p>	<p>Depending on the sensor connected to the MC608 converter, other certifications could be applicable; refer to the documentation on the specific sensor for more information: ATEX / IECEx: Directive 2014/34/EU - IEC 60079 - 0, IEC 60079 - 18 Use in potable water: DM 174 6/4/2004, NSF / ANSI61, WRAS, FDA Coating for aggressive environments: ISO 12944-2</p>		

3.3 GENERAL TECHNICAL FEATURES

The table below contains the technical data of the MC608 converter in all versions produced by BERMAD.

Features		MC608A	MC608B	MC608R	MC68P	MC608I
Casing		Aluminium IP68	Aluminium IP68	Aluminium IP68	Technopolymer IP54	SS IP54
Power supply	90...264 Vac	✓				✓***
	12/24 Vac/dc	✓			✓	✓
	Battery powered [estimated useful life: up to 10 years]		✓			
	Rechargeable battery + photovoltaic panel			✓		✓
Installation	Compact	✓	✓	✓		
	Remote	max 100m	max 30m	max 30m	max 100m	max 100m
Consumption		5W±10W				
Uscite I/O	Analog output 4-20mA	✓	✓ loop powered	loop powered if in battery mode	✓	✓
	Output AUX 24Vdc max 30mA	✓	✓	**	✓	✓
	Transistor output for pulses max 1000 Hz duty cycle max 50% only for positive instantaneous flow rate, positive negative (max 500 pulses/ second)	✓	✓	✓	✓	✓
	Digital programmable output for: <ul style="list-style-type: none"> • Reverse flow • Max flow rate threshold • Min flow rate threshold • Max/min flow rate threshold • Dosing • Interrupted excitation • Empty pipe 	✓		**	✓	✓
	Digital output in active freq. 0-10 kHz	✓		**	✓	✓
	All the outputs are opto-isolated.					
* = Optional ** = Only in rechargeable version *** Possibility to have a backup battery						

Features		MC608A	MC608B	MC608R	MC68P	MC608I
Serial communications	IrCOM interface	✓	✓	✓	✓	✓
	RS 485 - MODBUS RTU	✓		**	✓	✓
	Hart* communication	✓			✓	
	Integrated GSM/GPRS module*	✓	✓			✓
* = Optional ** = Only in rechargeable version						
Display	Graphic LCD 128x64 px, viewable area 50x25mm, white backlight	✓	✓	✓	✓	✓
Programming	Through 4 onboard buttons Through IRCOM / RS485 interface with relevant software	✓	✓	✓	✓	✓
Process memory	Memory 4 MB flash, 200.000 data lines	✓	✓	✓	✓	✓
Metrological certificate	OIML R49-1: 2013 - Class 2	Optional (depends on the connected sensor)				
Temperature fields		<ul style="list-style-type: none"> • Environment: -20 ÷ 60 °C (-4 ÷ +140 °F) • Liquid: -25 ÷ 80 °C (-13 ÷ +176 °F) • Storage: -40 ÷ 70 °C (-40 ÷ +158 °F) 				
Unit of measurement		ml, cl,dl, l, dal, hl, m3, l, in3, ft3, gal, bbl, oz, g, hg, kg, q, t, lb, Aft				
Optional modules		GSM/GPRS Pressure (1 input) and temperature (1 input)				
Totalizers		5 (2 positive, 2 negative, 1 NET)				
Alarms and status icons		Status icons displayed and alarms recorded in the data logger				
Self-check		Available alarms: <ul style="list-style-type: none"> • Excitation failure • Empty pipe with fourth electrode • Excessive ambient temperature • Overlapping pulses • Measurement error • Insufficient supply voltage 				
External check		Availability of the field verifier for calibration and on-site electronics status check				
Software for communication and programming		Commissioning (same setting of the meters) - Data printing for documentation - Data export (in CSV format) - Firmware update - Instantaneous flow rate reading - Reading and writing of non-volatile parameters - Internal data logger download - Display of stored events				
Signal cables		<ul style="list-style-type: none"> • BERMAD cables: • CA22 – cables for sensors with four electrodes 				
Pressure sensor		0...20 Bar; ½" GAS male, connector with factory installed fly coupling				
Temperature sensor		PT500: includes thermowell of ¼", length 50mm, diameter 6mm				

3.4 ACCURACY

3.4.1 Reference conditions:

- Measuring liquid: water
- Conductivity: >200 $\mu\text{s}/\text{cm}$
- Temperature: 20°C / 68°F
- Pressure: 1 bar / 14,5 psi
- Upstream diameter: ≥ 5 DN
- Downstream diameter: ≥ 3 DN

Model	Accuracy class		Graphics
MC608A/P/I	Class 02 2	$\pm 0,2\% \pm 2\text{mm/s}$	Fig. 10
MC608B/R	Class 05 5	$\pm 0,5\% \pm 5\text{mm/s}$	Fig. 11
MC608 connected to insertion sensor	Class 2 2	$\pm 2\% \pm 2\text{mm/s}$	Fig. 12



The following accuracy class refers to the measurement conditions during the calibration at the BERMAD test benches:

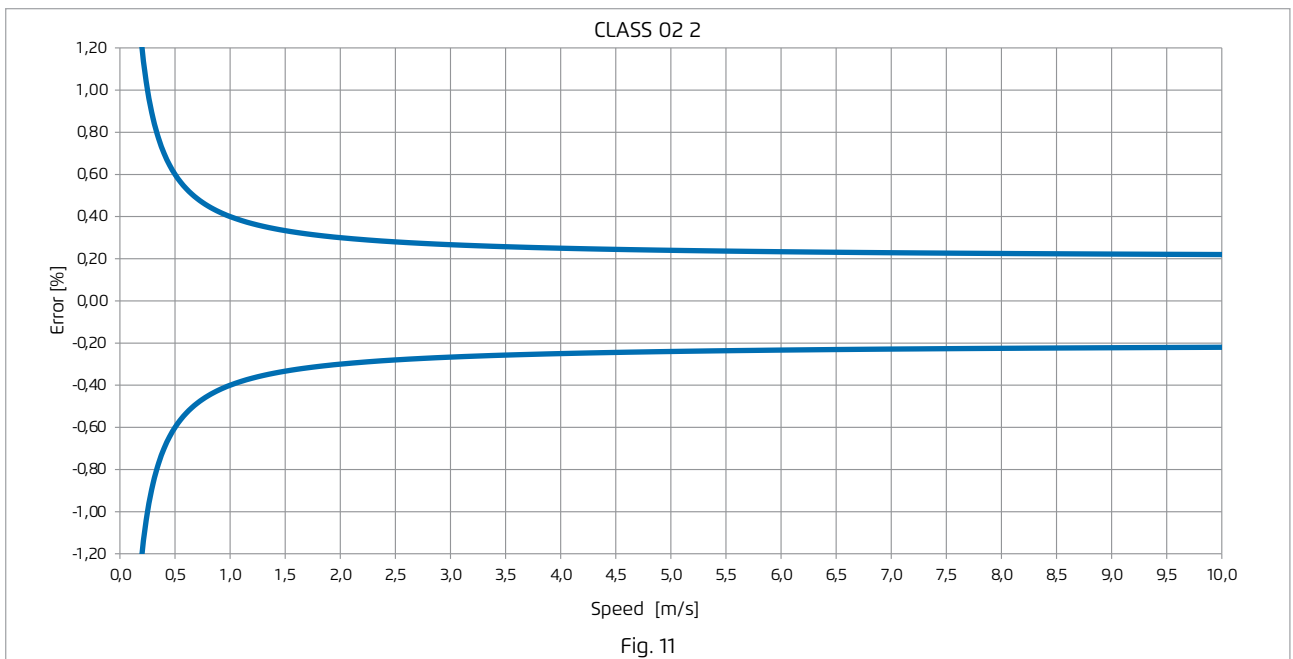

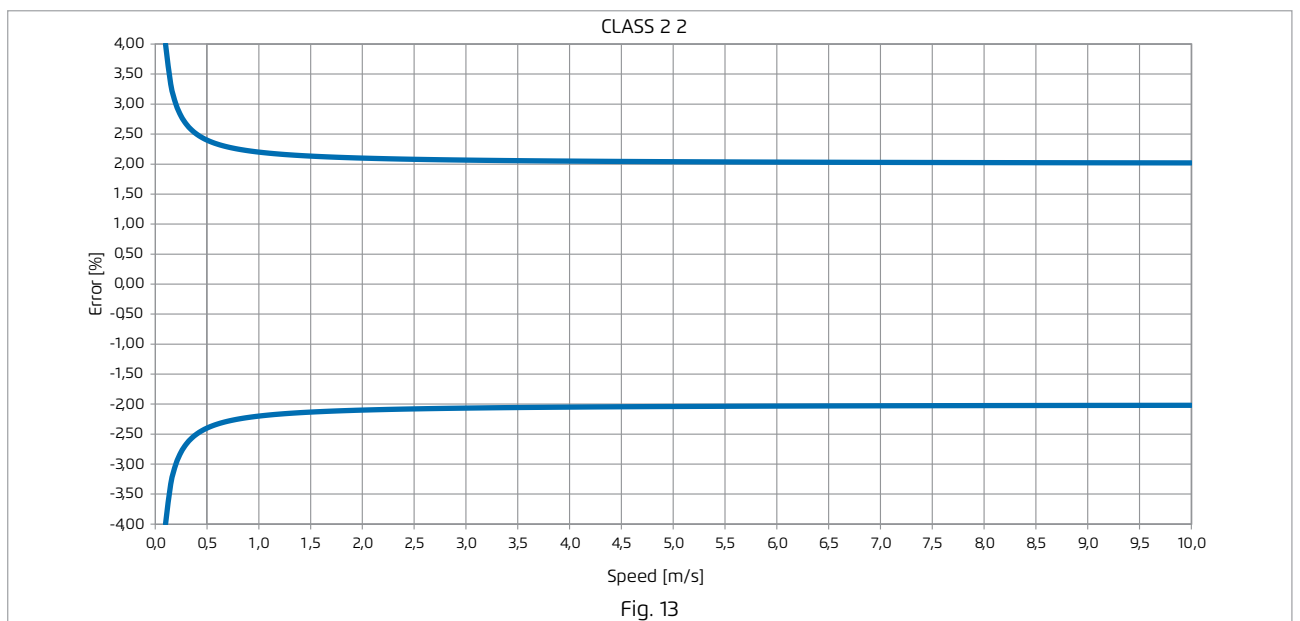
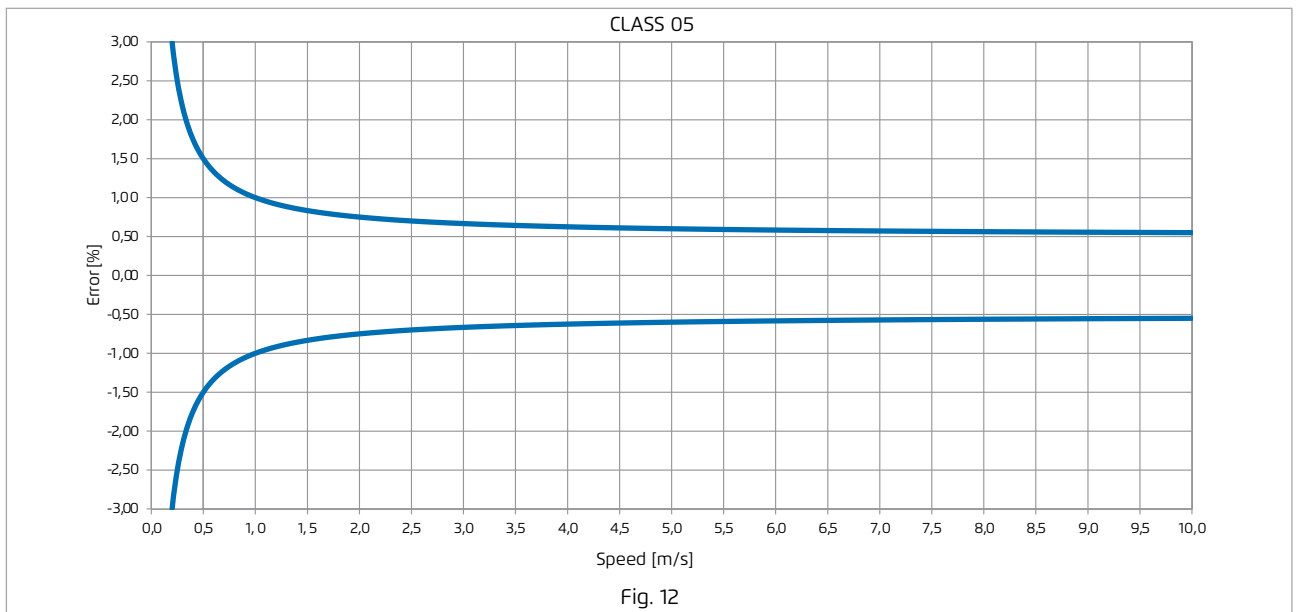

4 INSTALLATION

4.1 MOVING

 Given the small size and the low weight of the REMOTE version of the MC608 converter, there are no particular precautions/indications that need to be followed in order to carry out its movement and/or installation at the place of use.

 **CAUTION!** The compact version of the MC608 converter must be carefully moved so as not to cause damage to the sensor and connection flanges. Below you will find a description of the correct and incorrect handling of the compact converter.

The proper lifting method (for transport and installation) of the compact converter is shown in Fig. 14.

The flow meter must be lifted and transported by properly harnessing the device on the side parts of the flow meter, making sure that the slings (ropes, bands, etc.) are fixed to the appropriate eyebolts.

 **WARNING:** Do not raise the flow meter harnessing the converter (Fig. 15)!!

 Do not move the flowmeter with the lifting device if it is not in the original packaging (Fig. 16) or without an adequate support that ensures the required stability.

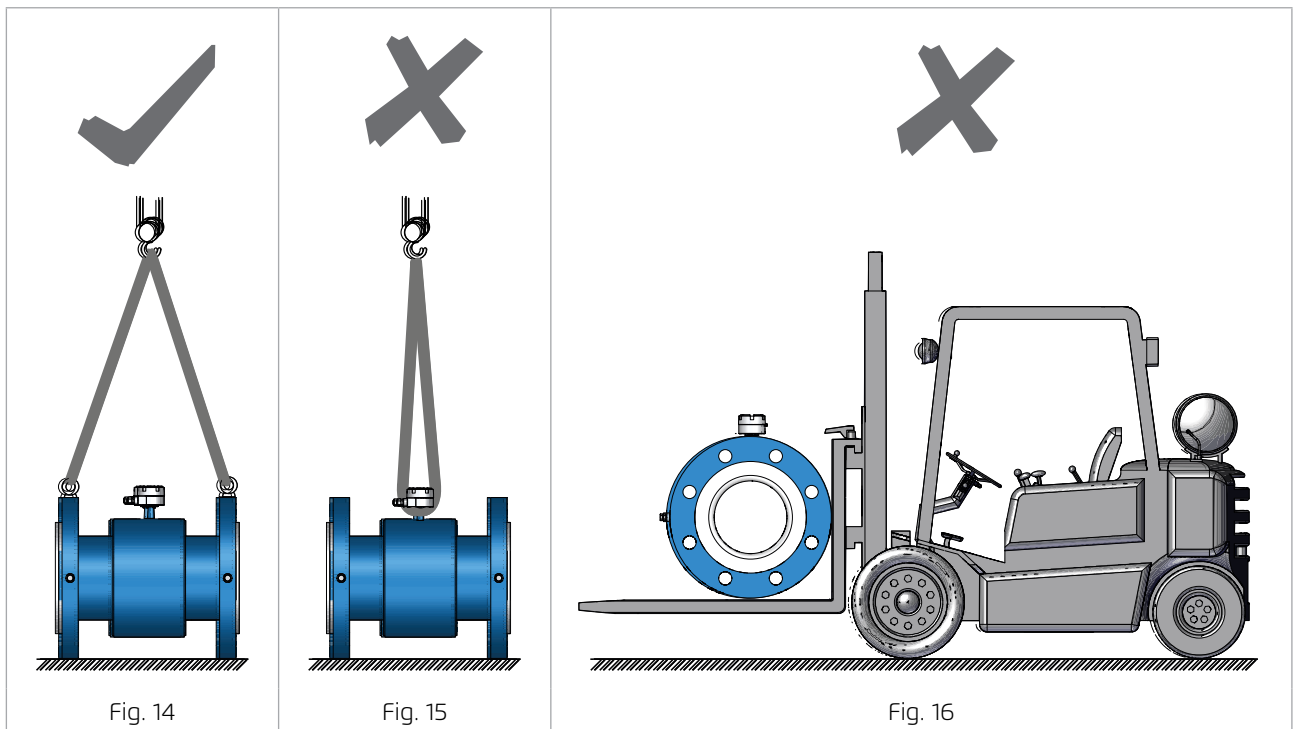

4.2 CONVERTER POSITIONING

4.2.1 Positioning/installation of the converter in COMPACT version

 For the correct positioning of the converter in the COMPACT version, refer to the INSTALLATION manual of the sensors where all correct and incorrect mounting positions are described and illustrated.

The converter display can be rotated 90°. Unscrew the front protection cover (see 1, Fig. 17) and remove it. Locate and pull out the converter display unit (see 2, Fig. 17) by 2 ÷ 3 cm, rotate it 90° in the most appropriate direction into the new position and insert it again. Put back the front protection cover (see 1, Fig. 17), tighten firmly to ensure sealing closure.

 **WARNING!** Do not rotate the display unit beyond 90 ° in order to prevent the cables connected to the sensor from turning. Also, do not pull out the display unit, otherwise voltage can be transmitted and damage to the wires connected to the sensor may occur.

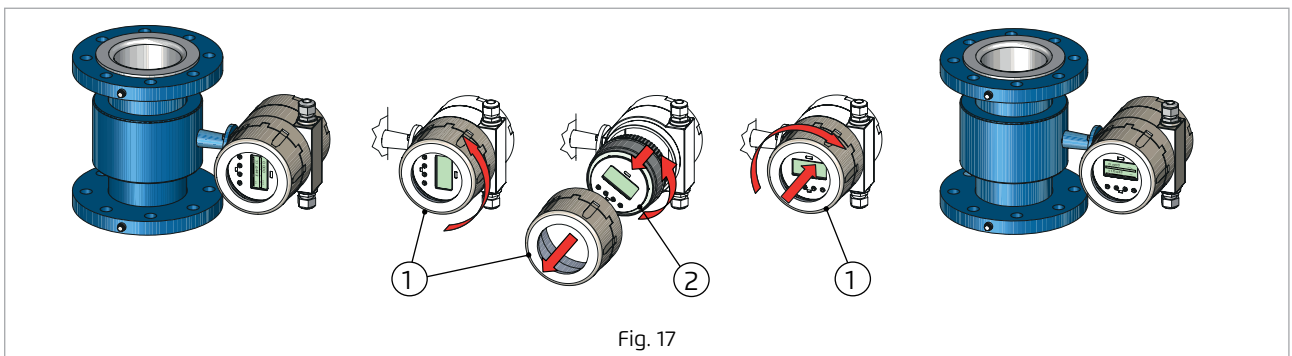

The converter can be rotated 90 degrees. Loosen the two screws on the lower part (see 1, Fig.17) positioned on the neck of the sensor and rotate the converter up to 90 ° appropriately. Once the new position is set, tighten the two screws (see 1, Fig. 18) to secure the converter to the sensor.

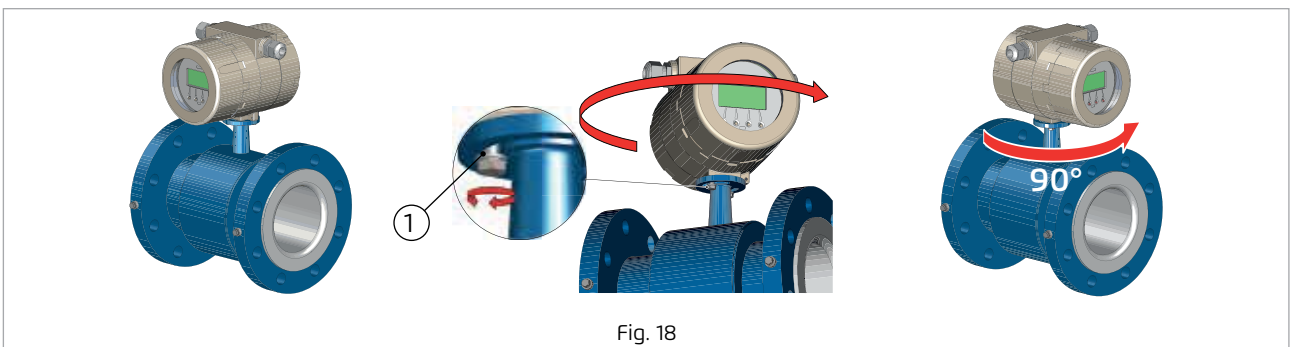

 **WARNING!** Avoid exposing the converter to excessive vibrations. Use the remote version in case vibrations may occur.

4.2.2 Positioning/installation of the converter in REMOTE version

The converter in REMOTE (distant) version can be installed on a pole/tube (Fig. 19) or on a wall (Fig.20) panel or control panel using the special brackets/flanges that were supplied with the converter.

Installation on a tube:

The device is designed to be fixed to a 2-inch diameter tube (see 1, Fig. 19). Bolt the brackets (see 2, Fig. 19) to the tube using two threaded hooks (see 3, Fig. 19). Then attach the converter (see 4, Fig.19) to the clamp.

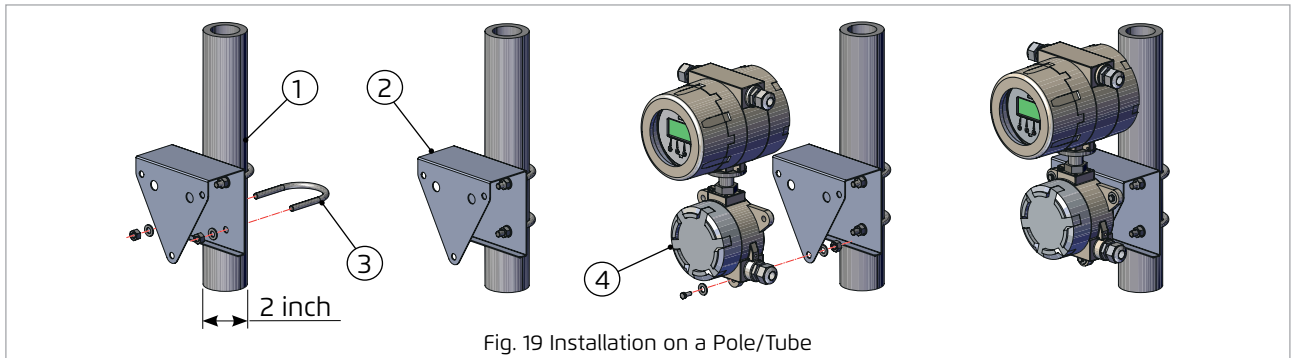

Installation on a wall:

Bolt the clamp (see 1, Fig. 19) to the wall using the appropriate plug screws. Then attach the converter (see 2, Fig. 19) to the clamp using the screws that were supplied with the converter.

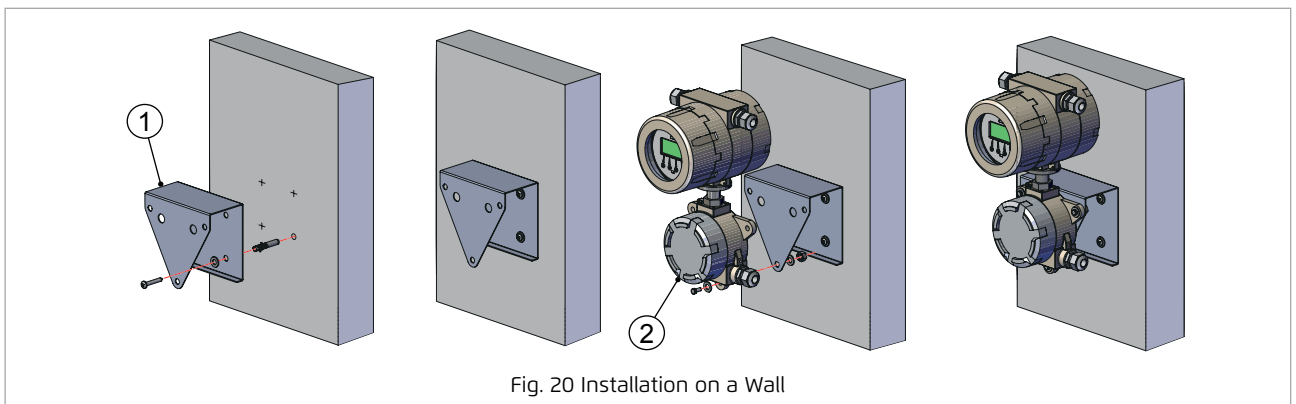

The mains powered converters in the REMOTE version (MC608A/P/I) can be installed up to 100 meters away from the sensor while battery powered converters can be installed up to 30 meters away from the sensor using the connection cable supplied by the manufacturer.

4.2.3 Relation between conductivity and cable length

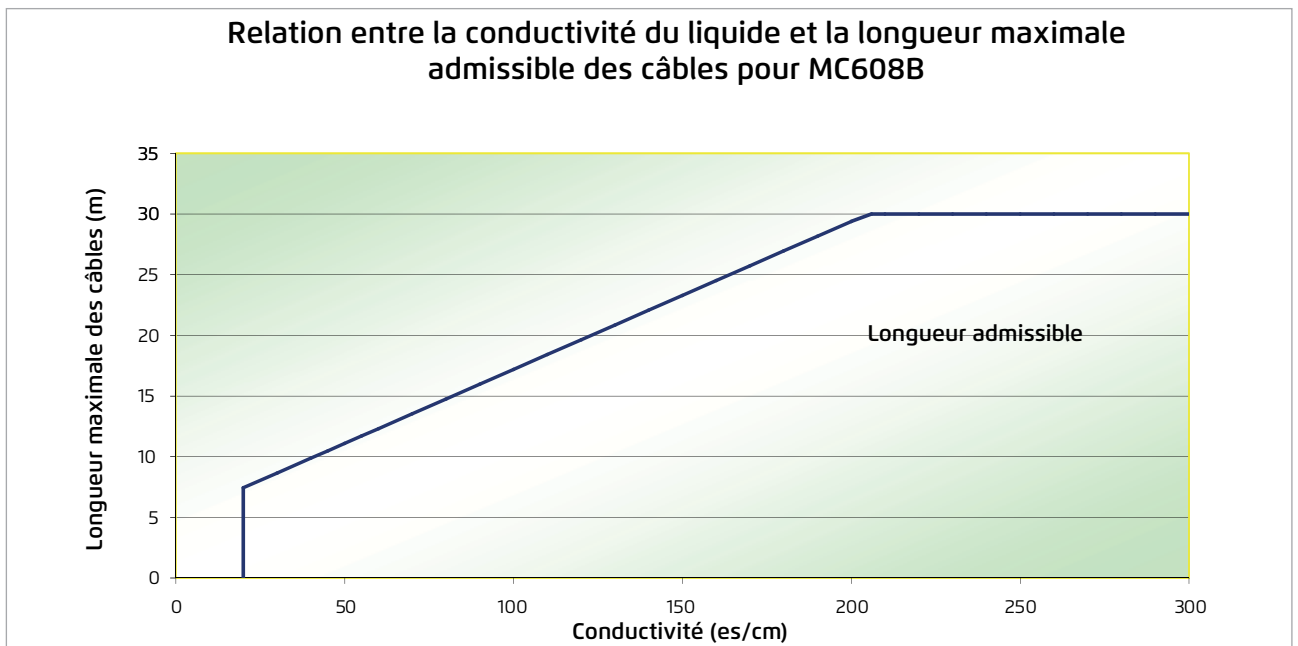
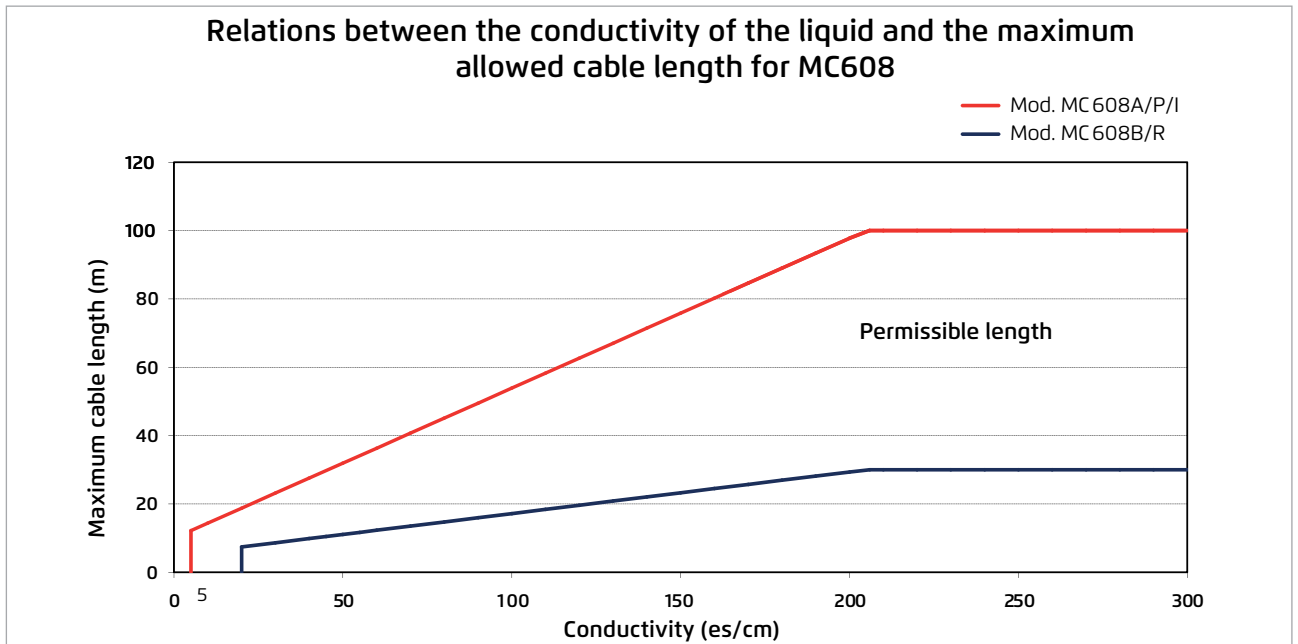

Fig. 21 Relation between conductivity and cable length

4.2.4 Installation of the solar panel on MC608R in the COMPACT version



The photovoltaic panel that powers the battery of the MC608R converter (compact version) is installed directly on the device casing using the special brackets which are provided in the special installation kit. The support brackets allow you to set the panel position in order to optimize solar radiation, which will depend on where it is installed.

Installation of the solar panel:

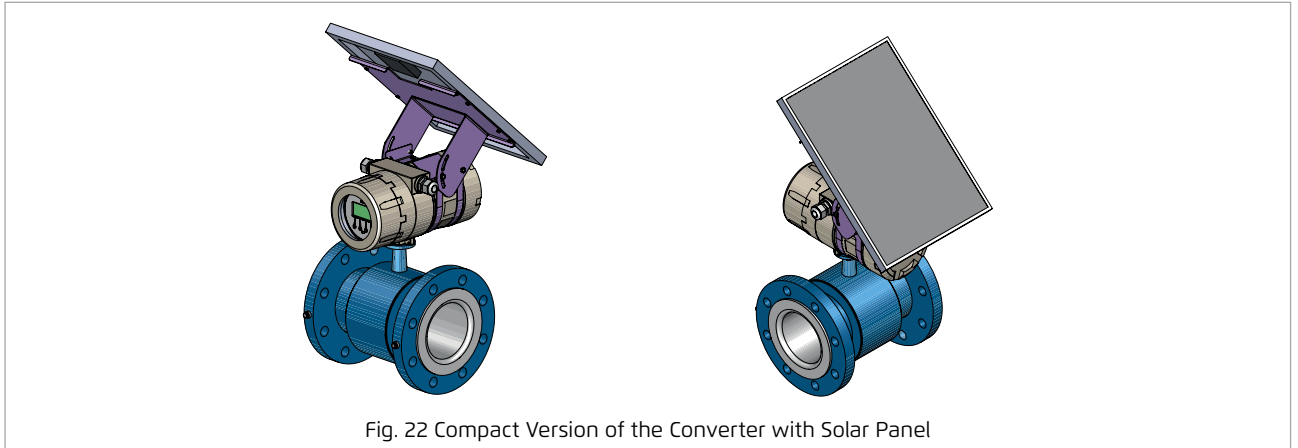
The photovoltaic panel is supplied in a separated kit. For the proper installation and operation, please read the instructions in the manual that was provided with the converter. (refer to the attachment).



4.3 ELECTRICAL CONNECTION

-  In order to properly connect electrical elements of the MC608 converter to the power supply, and to the junction box (in REMOTE version), please refer to the wiring diagram shown in paragraph 4.3.1 (Fig. 23).
-  The use of cables not supplied or certified by BERMAD may jeopardize the correct functioning of the system, and it will void the warranty.
-  All interventions on electrical connections must be performed only when the device is disconnected from the mains and/or battery.

4.3.1 Wiring diagram

-  All interventions carried out on the electrical junction box or electrical components must be performed by properly trained specialized personnel.

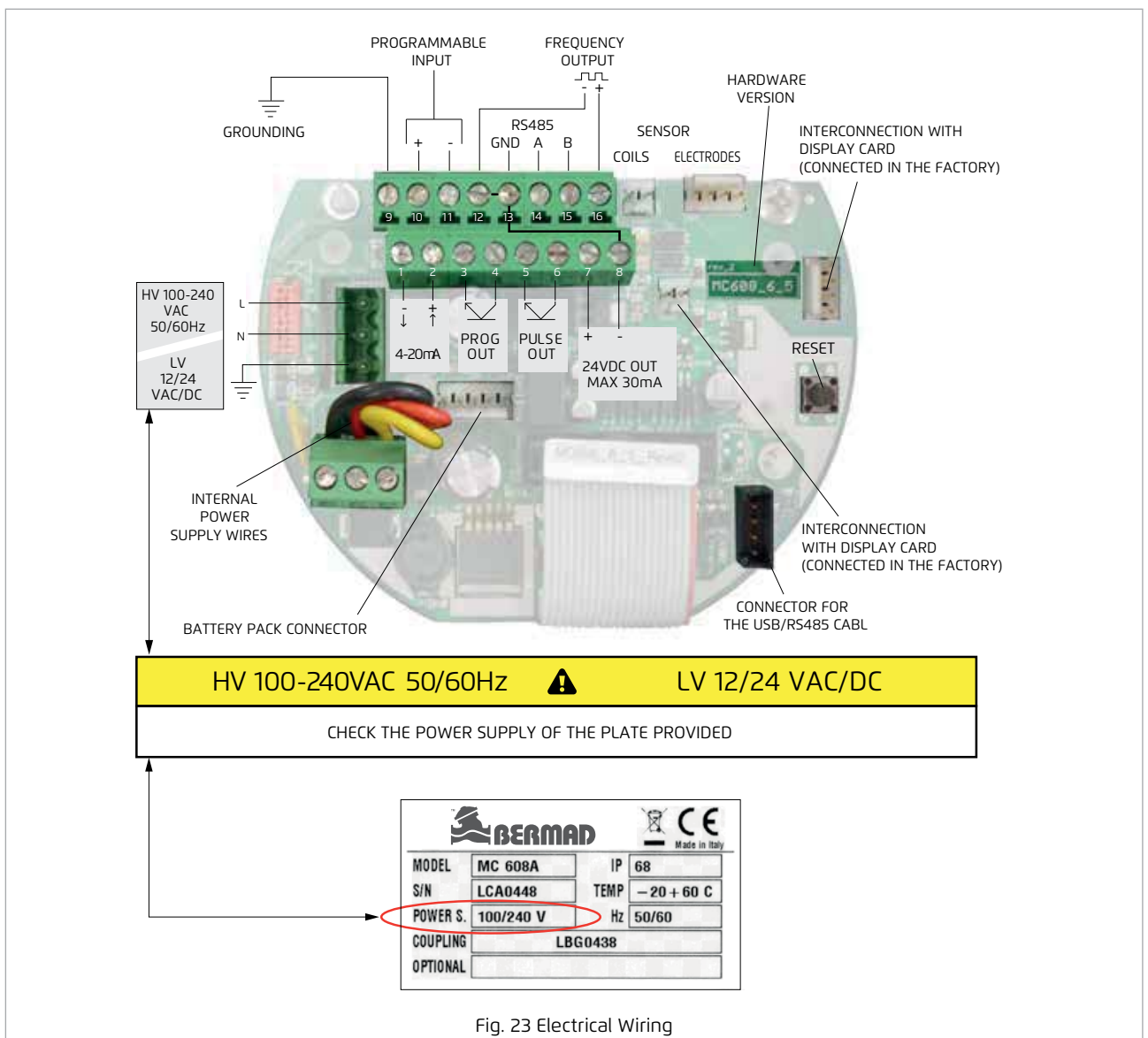
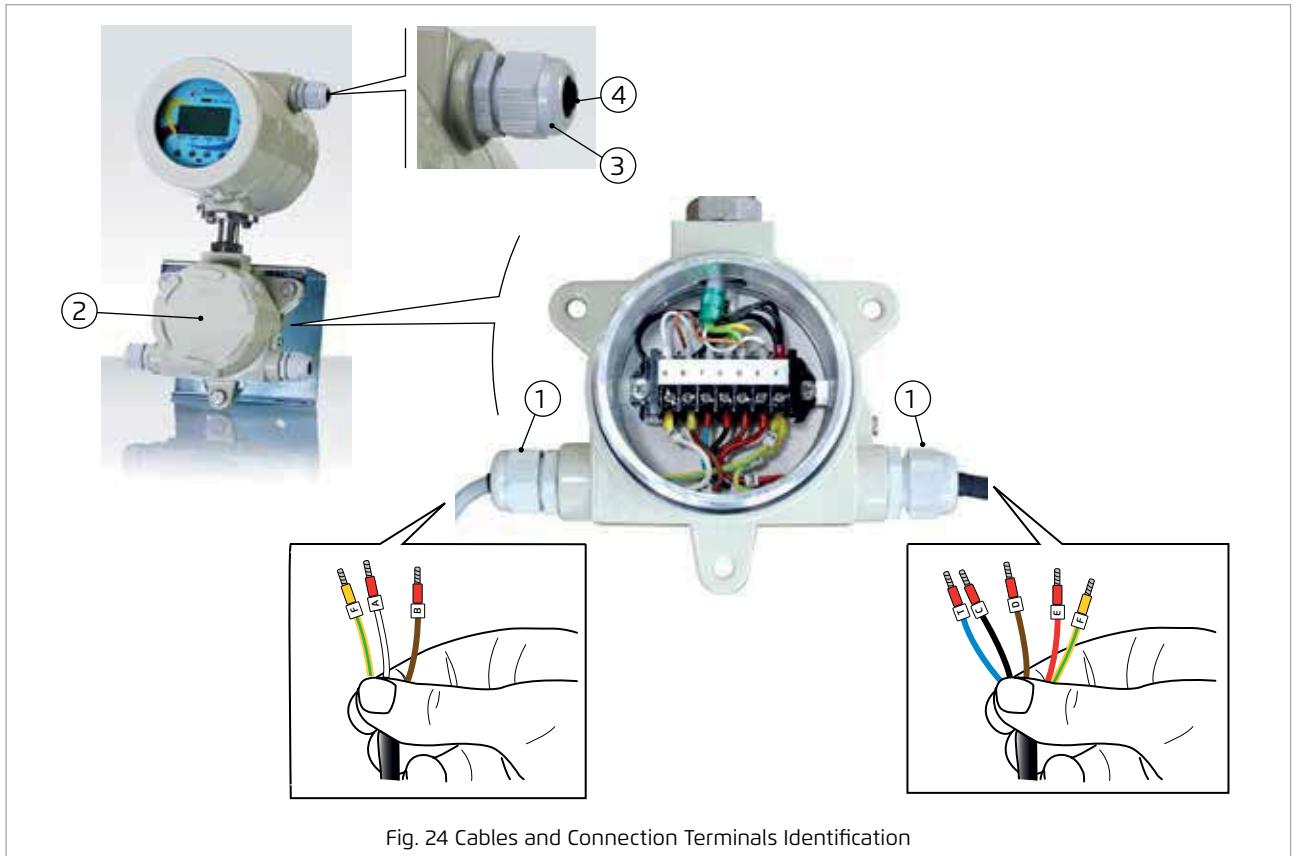

Fig. 23 Electrical Wiring

- i** The manufacturer has identified all the power cables and signal cables that have to be connected to the terminal block of the junction box (in case of REMOTE version) by marking them with bands (with letters) in order to ease the identification of the correct connection terminals (Fig. 24).



- ⚡** **CAUTION:** When all the necessary cables are connected, be sure to properly tighten the cable glands (see 1, Fig. 24) and the cover (see 2, Fig. 24) so as to guarantee good moisture and water resistance of the cables and electrical/electronic boards if the converter is installed outdoors.
- !** Any unused cable glands (see 3, Fig. 24) must always be closed with the relevant blind rubber sealings (see 4, Fig. 24).
- !** The used cable glands (see 1, Fig. 24) are suitable for multi-wire cables with a minimum diameter of 5 mm up to a maximum diameter of 12 mm (see 4, Fig. 24).

Note: The cables supplied by BERMAD are not suitable for being run directly underground and/or underwater, and must not have direct exposure to sunlight. The technician in charge must therefore provide suitable protections such as: corrugated pipes, raceways, or shielded cables.

Note: It is recommended to keep the separation cables detached from power cables and/or electromagnetic interference sources.

4.3.2 Connection to the sensor

Electrical connections on MC608 in COMPACT version

Before starting the converter, make the necessary connections to the outputs. For safety reasons, the power supply or the battery pack connected must be wired only after connecting the outputs.

Electrical connections on MC608 in REMOTE version (distant)



The access to the junction box is strictly limited to experienced technical personnel.



The cables that protrude from the sensor must be connected to the junction box positioned under the converter.

The MC608 converter can be installed on a wall or on a pole by using the brackets supplied with the remote version as shown in figures 19 and 20.

Be sure to connect the sensor to the converter with S/N shown in the "COUPLING" item on the plate.

This information can also be found in the converter, see menu -> Other -> System information. The same information can be downloaded to your laptop with the MC608 software.

To ensure regular operation, always use the manufacturer's signal cables that were supplied with the converter.

4.3.3 Connection options I/O

4.3.3.1 Pulse output

Passive transistor output

Instrument connected to active input

The connected instrument (PLC/external pulse counter) is an active digital input which supplies voltage required to detect the pulses. The MC608 acts as a digital switch (logical level).

[Voltage 5-30Vdc; maximum electrical current 50mA].

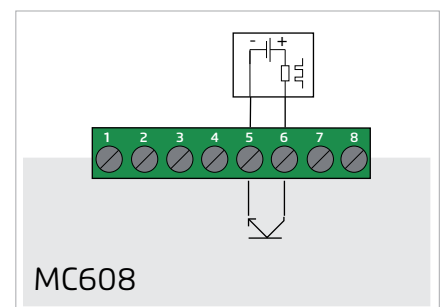

Fig. 25

Instrument connected to passive input

The connected instrument (PLC/external pulse counter) is a passive digital input that accepts the voltage provided by the external power supply in use.

[Voltage 5-30Vdc; maximum electrical current 50mA].

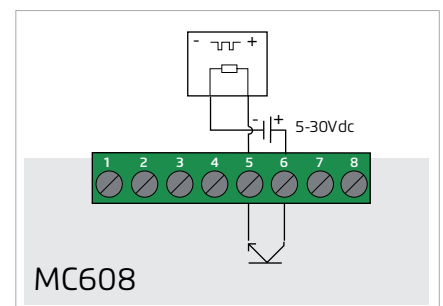

Fig. 26

Active transistor output (MC608A/P/I)

The connected instrument (PLC/external pulse counter) is a passive digital input which accepts a 24V voltage. It DOES NOT have to provide ANY additional voltage. The internal 24Vdc power supply is used to supply necessary voltage.

[Voltage 24Vdc; maximum electrical current 30mA - See "NOTE 1"].

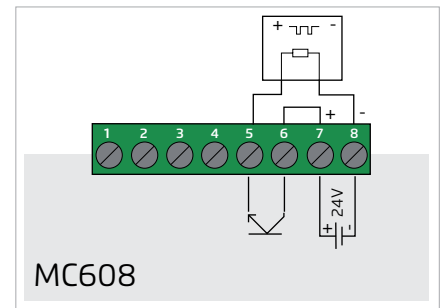

Fig. 27

4.3.3.2 Programmable output

Passive transistor output

Instrument connected to active input

The connected instrument (PLC/external pulse counter) is an active digital input which supplies the voltage required to de-tect the pulses. The MC608 acts as a digital switch (logical level).

[Maximum voltage: 5-30Vdc; maximum electrical current 50mA].

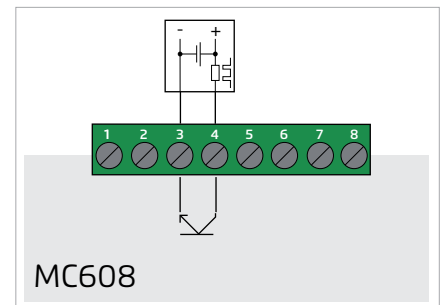

Fig. 28

Instrument connected to passive input

The connected instrument is a passive digital input which accepts the voltage provided by external power supply in use.

[Voltage 5-30Vdc; maximum electrical current 50mA].

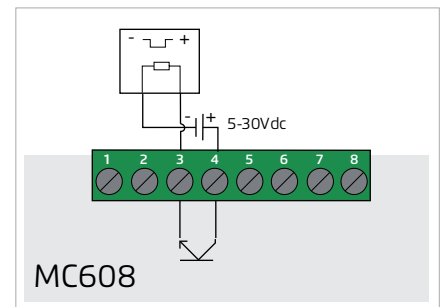

Fig. 29

Active transistor output

Active transistor output (MC608 starting from version 6-3)

The connected instrument is a passive digital input which accepts a 24V voltage. It DOES NOT have to provide ANY additional voltage. The internal 24Vdc power supply is used to provide necessary voltage.

[Voltage 24Vdc maximum electrical current 30mA - See "NOTE 1"].

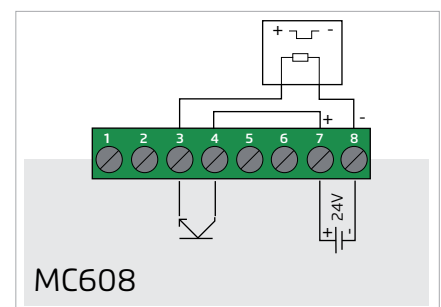

Fig. 30

4.3.3.3 Output 4...20mA

Loop powered

The receiver 4...20mA connected to the instrument is loop powered, which feeds by itself the current in loop.

[Loop voltage 24Vdc; maximum impedance 800 ohm].

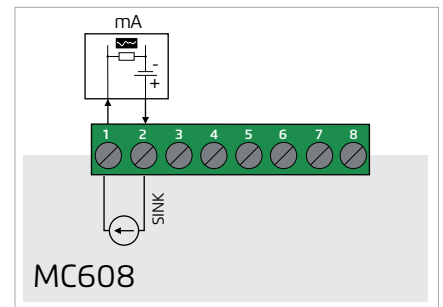

Fig. 31

Active (MC608A/P/I)

The receiver 4...20mA connected to the instrument is a pas-sive milliamp-meter; the internal MC608 24Vdc power supply must be connected as shown in Figure 32.

[Loop voltage 24Vdc; maximum impedance 800 ohm].

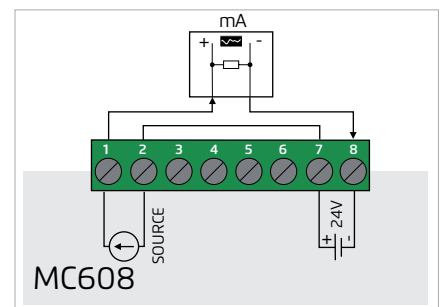

Fig. 32

Note 1: The pulse output and the output 4...20 mA is available only in loop powered mode in converters MC608B or MC608R.

4.3.3.4 MODBUS RS485 interface

The MODBUS RS485 interface is available between the terminals 13 - 14 - 15 which are positioned in the converter board. (Fig. 33).

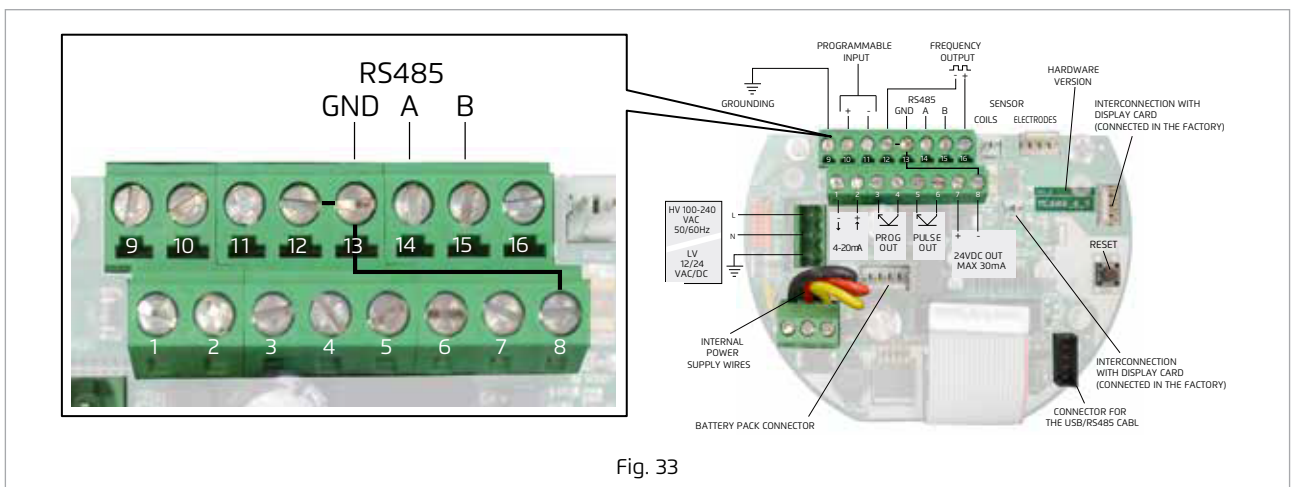

Fig. 33



The communication interface RS485 is used in combination with MC608 software or with other computer systems compatible with the MODBUS RTU standard; for further information, see the MODBUS address manual.

4.3.4 Electrical grounding of the converter

The purpose of grounding is to protect the system from external electromagnetic interference and to set the measurement reference of the meter. To achieve this requirement, a clean earth connection with the lowest possible resistance is required. We recommend using at least one 4mm^2 / AWG11 cable to make the grounding connections. If the liquid is not electrically connected to the pipes (in plastic or with internal coating) grounding rings are required. Absent or incorrect grounding will result in unpredictable failure (Fig. 34).

Note: In the MC608 REMOTE version, the sensor and the converter must be grounded using two separate wires (Fig. 34). Avoid placing the signal and power cables close together to minimize interference.

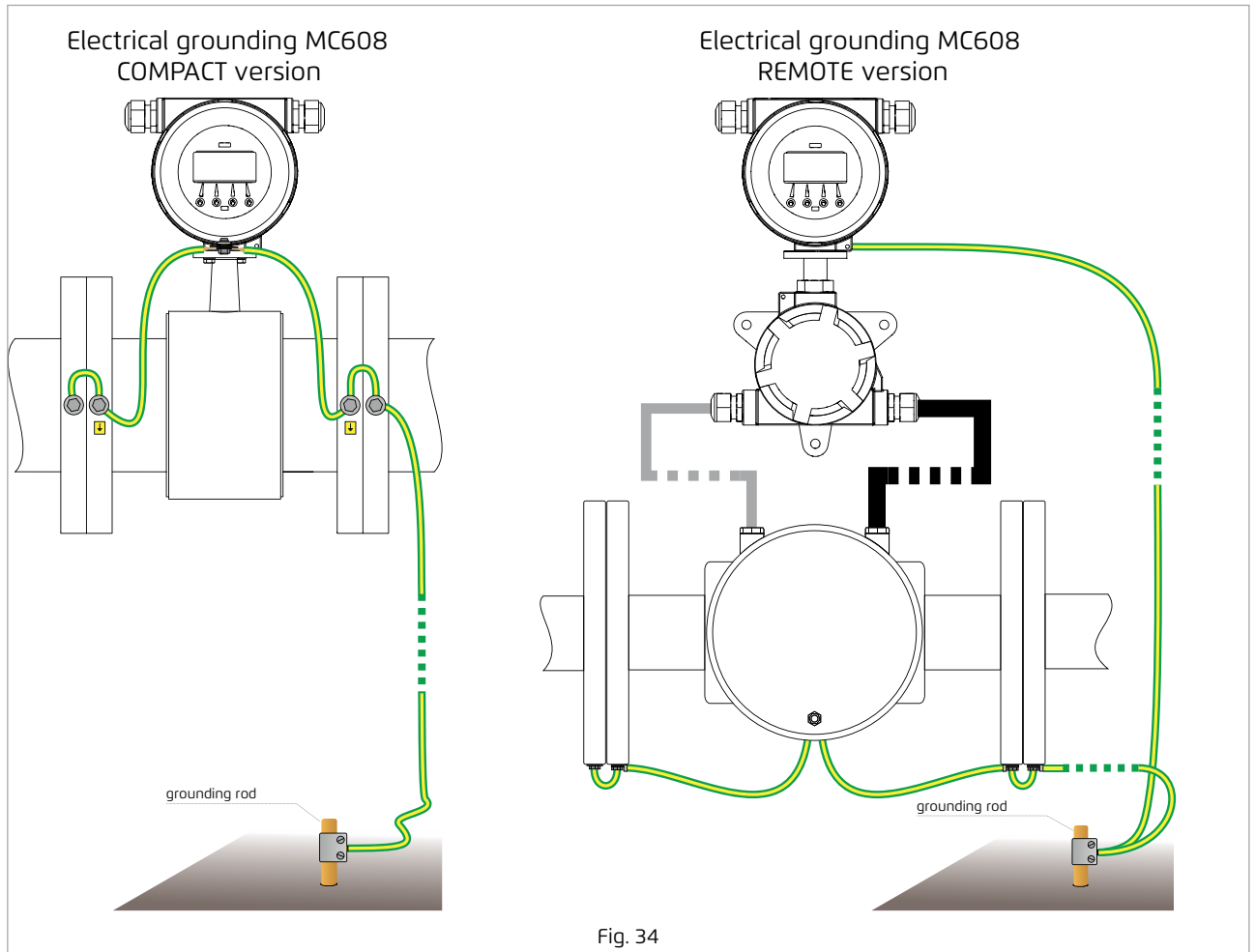

Fig. 34



For a correct device operation it is necessary to carry out a connection in a well-executed manner.

4.3.5 Connection to the power supply



THE ELECTRICAL CONNECTION OF THE DEVICE MUST BE CARRIED OUT BY QUALIFIED TRAINED PERSONNEL.

Make sure that all electrical connections have been made correctly before connecting the unit to the power supply. Check the supply voltage on the plate.

The unit may be supplied with voltage:

VERSION	POWER SUPPLY TYPE
MC608A	90 ... 264 Vac or 12 ... 24 Vac/dc
MC608B	Powered by lithium battery
MC608R	Powered by a rechargeable lithium battery (Power supply and battery charging is supplied by the solar panel)
MC608P	12 ... 24 Vac/dc
MC608I	90 ... 264 Vac (With lead backup battery) or 12 ... 24 Vac/dc (With lead backup battery) or Powered by a rechargeable lithium battery (Power supply and battery charging is supplied by the solar panel)

5 MC608 CONVERTER PROGRAMMING

5.1 CONVERTER CONFIGURATION METHODS

The configuration of the MC608 converter can be performed in three different ways:

<p>1) Using 4 buttons positioned on the front display of the converter (see 1, Fig. 30), unscrewing the front panel glass (see 2, Fig. 35).</p>	<p>2) From the PC using the RS485 MODBUS output (see electrical connections) and the configuration software BERMAD MC608. The USB cable adapter (Fig. 36) is available from the manufacturer on request.</p>	<p>3) From the PC via the infra-red port located on the front of the converter, above the display and the BERMAD MC608 software configuration program using the IrCOM cable (Fig. 37) available from the manufacturer on request.</p>
 <p>Fig. 35 Configuration Buttons</p>	 <p>Fig. 36 USB-MODBUS Cable</p>	 <p>Fig. 37 IrCOM Cable</p>

i The BERMAD MC608 software can be downloaded from our website www.bermad.com accessing the download area. It is also available on the USB flash drive included in the packaging.

5.1.1 Software MC608 configuration

Install the MC608 software on the PC, run the program, connect the unit to the PC. In case you are using a battery-powered sensor, the activation should be completed as follows:

i **Activation of the MC608B or MC608R in battery mode:**

Normal operation of the MC608B is "sleep mode." This mode preserves battery life while ensuring the functional operation of the product. To recall the unit for the next programming, use the magnetic key (see 1, Fig. 38) provided only with the MC608B or MC608R and slide it vertically on the front panel of the converter, to the point marked with: "ACTIVATE" (Fig. 39). As an alternative, push one of the 4 configuration buttons



! You may need to change the input port (see 4, Fig. 40). Use the COM PORT command of the software to select the correct input. It is usually the port with the highest number.

Select the communications RS485 (see 1, Fig. 40) or infra-red (see 2, Fig. 40) and click the button CONNECT (see 3, Fig. 40).



Fig. 40 Connection Window BERMADE MC608

i It is possible to change the display language of the software menu by following this path: "Settings" > "Change Language" and choosing one of the available languages (Fig. 41).

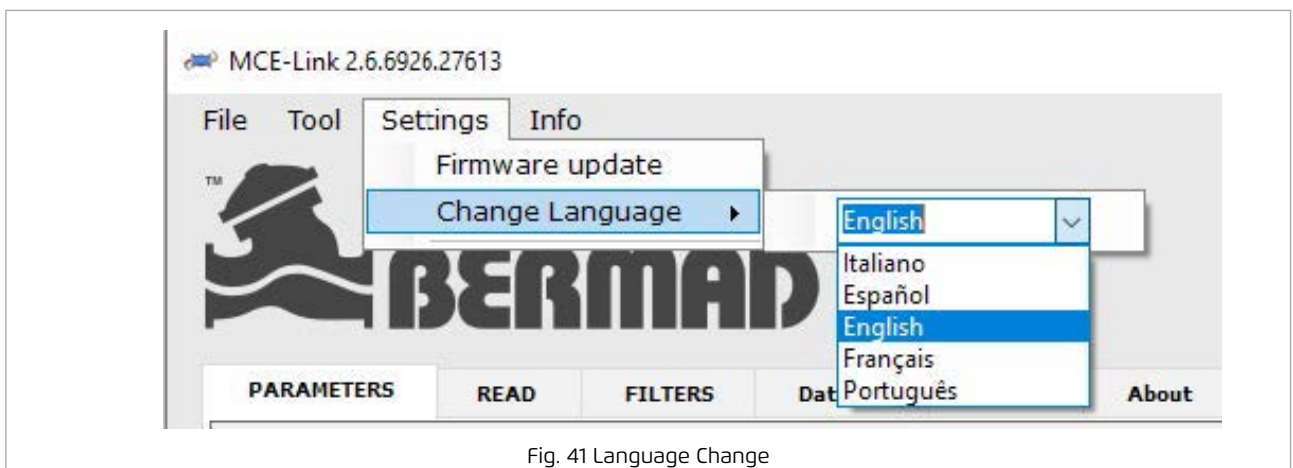

Fig. 41 Language Change

5.1.2 Converter Password

The converter has been created with three different protection levels:

- Level 1: 608111
- Level 2: 709222
- Level 3: 231042

i The passwords can also be changed. To change the password, go to the menu and select "memory" > "sett. password."

Figure 42 shows the main screen of the BERMAID MC608 software properly connected to the converter. By accessing various pages, it is now possible to view the data and modify the operating parameters.



Fig. 42 Main Screen

5.2 PROGRAMMING



As already described in the previous paragraph, the converter can be programmed by connecting the instrument to a PC on which the “MCE-Link” configuration software is installed or by directly using the four buttons on the front of the converter.

To access the menu from the converter, unscrew the protection cover (see 1, Fig. 43) and press the button function positioned under the item “MENU” (see 2, Fig. 43)

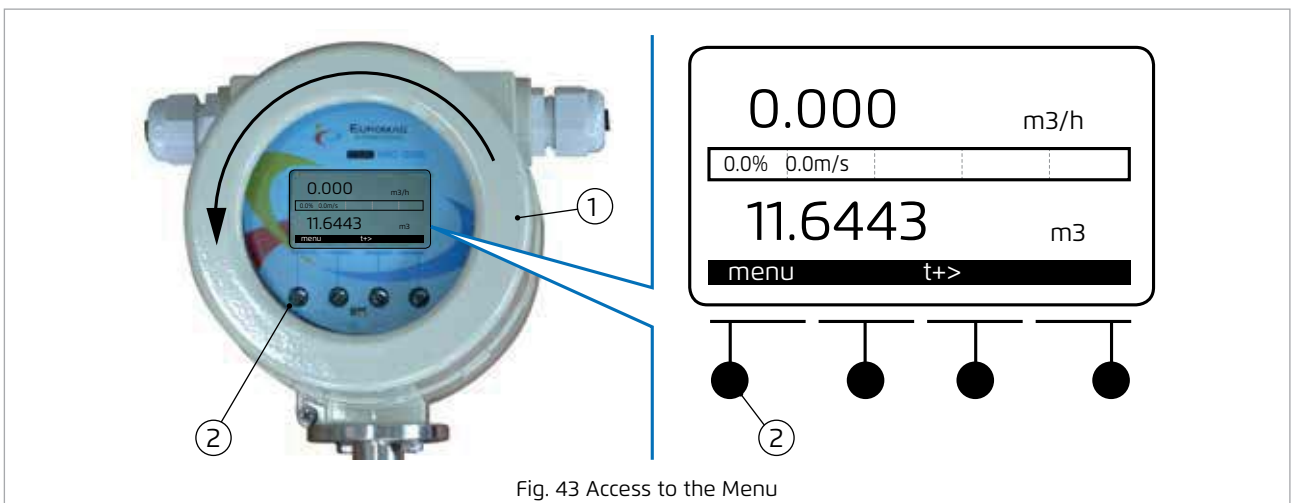

Fig. 43 Access to the Menu

5.2.1 Data display description

With reference to Figure 44, the converter display is divided into 3 main areas:

- The top area (see 1, Fig. 44) contains the status information symbols, with indicators of battery life (MC608B and MC608R), power supply (MC608A) or power supply and battery recharge (MC608R), as well as the alarm symbols and instantaneous reading of the flow rate (for more information on the icons that can be displayed and their meanings see paragraph "5.2.2 Identification and description of status icons").
- The central area (see 2, Fig. 44) contains a linear graph of the flow rate expressed as a percentage of the full scale
- The bottom area (see 3, Fig. 44) can be selected by the client and possible options are:
 - T+ total positive counter.
 - P+ partial positive counter.
 - T- total negative counter.
 - P- partial negative counter.
 - NET – Net totalizer.
 - Date and time and temperature and pressure indicator (the latter available with optional module).

To choose the required value simply click the button that corresponds to the arrow and choose the value, or select the menu -> Preferences -> Display -> Last line.

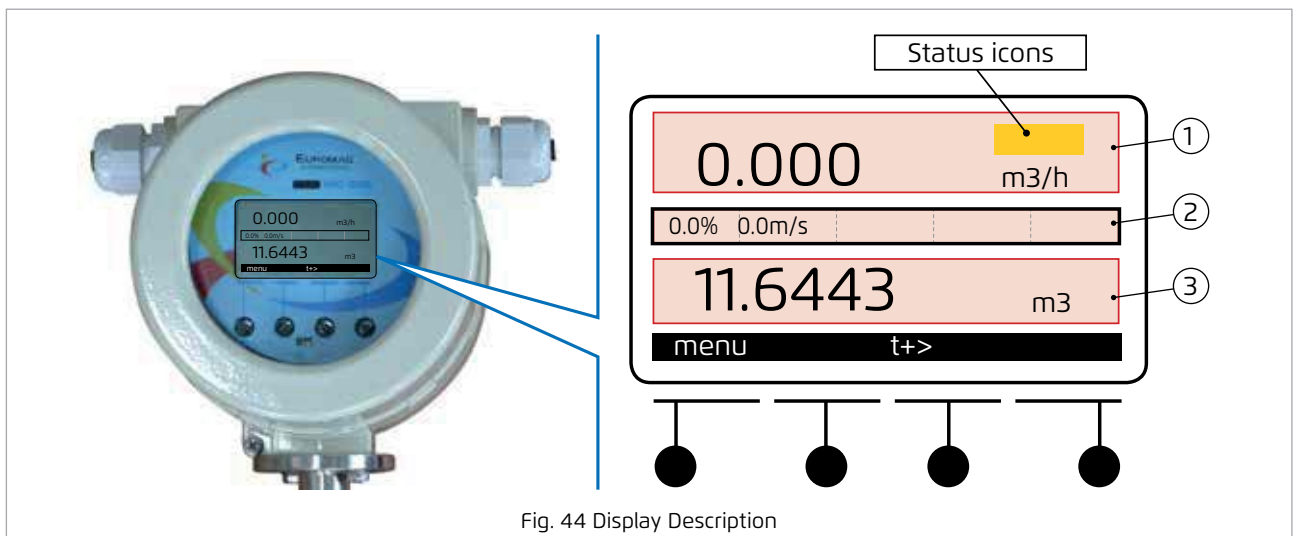

Fig. 44 Display Description

5.2.2 Status icons identification and description



The icons shown on the display offer the user immediate information on the power supply status and on the possible problems that may occur during the operation. It is therefore very important to know in advance the meaning of each symbol.

POWER SUPPLY ICON STATUS	
	Main power supply
	Battery power supply (remaining)
	Battery charging (rechargeable version)
ALARM STATUS ICONS	
	Flow rate > MAX threshold
	Flow rate < MIN threshold
	Excitation failure
	Measurement error
	Empty pipe
	Accumulation pulses alarm
	Board temperature alarm (shown in the measurement unit set)
	Low voltage alarm
COMMUNICATION STATUS ICON	
	Data connection in progress

5.2.3 Device programming/configuration menu

The following list shows the first-level items of the converter configuration menu:

MENU:

- PREFERENCES
- COUNTERS
- PARAMETERS
- I/O
- OTHER
- MEMORY



Every first-level item allows access to their own submenu. The complete menu of the AVAILABLE FUNCTIONS is shown in the following table.

OPTIONS (See Par. 5.3.1)	TECHNICAL UNITS	Flow rate unit
		Flow rate time base
		Counters unit
		Pulses unit
		Specific weight
		Temperature unit
	DISPLAY	Measuring time
		LCD backlight level
		Backlight off
	VIEW OPTIONS	LCD contrast
PRESSURE ZERO	Last line	
TAG		
FULL SCALE FLOW RATE		
LANGUAGE		

COUNTERS (See Par. 5.3.2)	T+
	P+ (ZERO SET UP)
	TP-
	(ZERO SET UP)

PARAMETERS (See Par. 5.3.3)	KA ADJUSTMENT	
	DIAMETER SETUP	
	FILTERS SET UP	Flow cut off
		Damping
		Bypass
		Peak cut off
		Measure average
	LINE FREQUENCY	
	ZERO FINDER	
	FLOW RATE ALARMS	MAX flow rate threshold
MIN flow rate threshold		
EMPTY PIPE THRESHOLD		



I/O (See Par. 5.3.4)	PULSE OUTPUT	Pulse quantity
		Pulses time ON
		Reverse flow rate
		Active pulses output
	FREQUENCY OUTPUT	Full scale frequency
		Active frequency output
	PROGRAM. OUTPUT	Enabled/disabled
		Reverse flow
		Max flow rate threshold
		Min flow rate threshold
		Max/min flow rate threshold
		Dosing
		Excitation failure
PROGRAM. INPUT	Empty pipe	
	All alarms	
	Enabled/disabled	
	Resetting p+	
BATCHING	Resetting p-	
	Resetting p+/p-	
PROGRAMMABLE OUTPUT LOGIC	P reset and block	
OTHER (See Par. 5.3.5)	SYSTEM INFO	
	TIME/DATE	
	RESERVED	
	GRAPH	
	COMMUNICATION	Baud rate RS485
	MODBUS address	
	Data connection	
MEMORY (See Par. 5.3.6)	LOAD USER COPY	
	SAVE USER COPY	
	FACTORY SETTINGS	
	DATALOGGER	Show last row
		Complete deletion
		LOG interval
PASSWORD SET UP		
NEW BATTERY		

5.3 MENU ITEMS DESCRIPTION



The description of all menu items already listed in a schematic way in paragraph 5.2.3 as follows:

5.3.1 MENU → PREFERENCES

TECHNICAL UNITS	
Flow rate unit	Allows you to select volume technical unit for instantaneous flow rate.
Flow rate time base	Allows you to select time base for instantaneous flow rate.
Counters unit	Allows you to select volume technical unit for the counters.
Pulses unit	Allows you to select volume unit for the pulses.
Specific weight	Allows you to insert the specific weight of the liquid in use.
Temperature unit	Allows you to change wanted temperature unit.
MEASURE INTERVAL	
Measuring time	Valid only for battery-powered versions MC608B/R; allows you to select the measuring time of the system among 10/15/30/45/60/120/180/240/300/360/420/480 seconds. Warning! Factory set time is 45 seconds. Any reduction of this factor will affect battery life when using the MC608B in battery mode.
SCREEN	
LCD backlight level	Valid only for battery-powered versions MC608B/R; allows you to set the display backlight.  Warning! Any increase in this factor will affect battery life when using the MC608B or MC608R.
Backlight OFF	Allows you to increase or reduce time to the screen turning off.  Attention! Warning! Any increase in this factor will affect battery life when using the MC608B or MC608R.
LCD contrast	Allows you to adjust the contrast value of the screen.
VISUALIZZAZIONE	

MENU → PREFERENCES

Last line

Allows you to define the display default information with following options:

- T+ : Total positive counters
- P+ : Partial positive counters
- T- : Total negative counters
- P- : Partial negative counters
- NET : Net totalizer
- Board date time/temperature
- Process temperature/pressure (with optional module)

PRESSURE RESETTING

This menu can be used to reset the pressure value in case of electronics with integrated pressure module.

TAG

This menu can be used to insert a displayable TAG number on the converter main screen.

FUL SCALE FLOW RATE

Allows you to change the full scale flow rate. The standard full scale flow rate is calculated by considering a speed of 10 m/s.



Here below you will find possible units of measurement for full scale and the corresponding conversions in "m³" and "kg."

UNIT	EQUIVALENTS	UNIT	EQUIVALENTS
ml	1e-6 m ³	gal USA, gallons USA	3,78541 m ³
cl	1e-5 m ³	bbl oil, oil barrel	158,984 m ³
dl	1e-4 m ³	oz US, fluid ounce US	0,02957 m ³
l	0.001 m ³	g	0,001 kg
dal	0.01 m ³	hg	0,1 kg
hl	0.1 m ³	kg	1 kg
m ³	1 m ³	q	100 kg
kl	1,000 m ³	t	1000 kg
in ³ , cubic inches	1,63871e-5 m ³	lb, pound	0,45359 kg
ft ³ , cubic feet	28,31685 m ³	acre-foot	1233,4818 m ³

LANGUAGE

Allows you to choose one of the following menu languages:

- ENGLISH
- ITALIANO
- ESPAÑOL
- PORTUGUÊS
- FRANÇAIS

5.3.2 MENU → COUNTERS

MENU → COUNTERS	
T+	Total positive counter.
P+	Partial positive counter, resettable to zero.
T-	Total negative counter.
P-	Partial negative counter, resettable to zero.
NET	Net counter: difference between T+ and T-.

Various counters with the MC608 converter are available: two positive (total and partial) and two negative (total and partial).

i **Only partial counters can be set to zero.**

To set the counters to zero from the MC608 software, access the screen "READ" and press the button "ZERO" (see 1, Fig. 45) that refers to the partial counter that you want to reset.

The same screen also displays a linear bar (see 2, Fig. 45) which shows the percentage of the instantaneous flow rate in relation to the full scale capacity set in the converter.

The same screen also displays in a special box (see 3, Fig. 45) of the converter: the current "Date" and "Time." In an additional module, external temperature or system operating pressure data are available

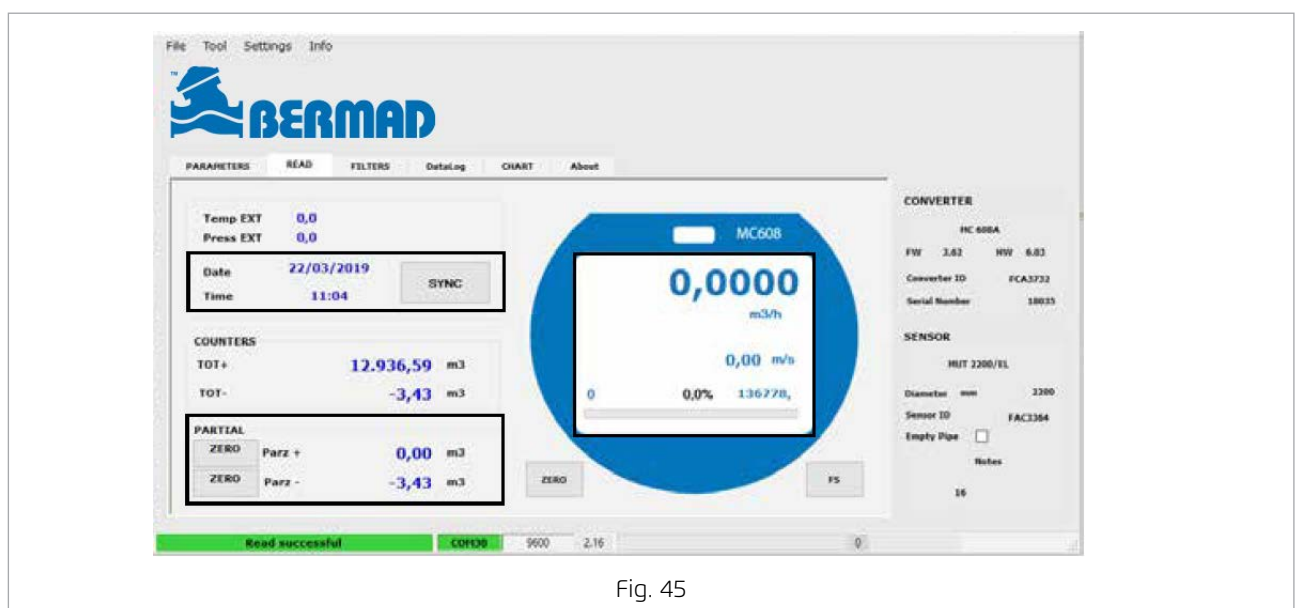





Fig. 45

5.3.3 MENU → PARAMETERS

MENU → PARAMETERS	
KA ADJUSTMENT	
	<p>It allows the adjustment of the calibration factor KA.</p> <p> Caution! Changes to the KA factor can only be made by authorized persons. The KA factor must be the same as the coupled sensor; check it on the flow meter plate.</p>
DIAMETER ADJUSTMENT	
	<p>It allows the diameter adjustment. In case of insertion flow meter, please enter the real inner diameter value of the pipe in this menu.</p>
FILTER SETUP	
	<p> Filters should be adjusted only if strictly necessary. Factory settings are already calibrated for proper operating conditions.</p>
Flow cut off	<p>In this sub-menu you will find a value expressed as a percentage of full scale: if the actual flow rate is less than this value, the device will show a flow equal to 0.</p> <p> Should you need to reduce the flow cut-off filter, it means that the speed of the liquid is lower than the recommended one necessary for precise measuring.</p>
Damping	<p>Indicates the number of mediated samples which are used to obtain instantaneous flow rate shown on the display and transferred to the 4-20 mA outputs and frequency. To increase the stability, increase the value in this sub menu.</p>
Bypass	<p>A value expressed in percentage is inserted in this sub-menu. It represents a threshold beyond which the damping filter IS NOT applied.</p> <p>For example:</p> <ul style="list-style-type: none"> ■ If the value of 50% has been selected: ■ <u>IF</u> the flow rate varies by 50% more than previous value ■ <u>THEN</u> the indicated flow rate will have the real value. ■ <u>OTHERWISE</u> the damping filter will be applied, in other words, the indicated flow rate will reach slowly the real value.
Peak cut-off	<p>In this sub-menu you will find a value expressed as a percentage of full scale. If the measurement of the flow rate shows amplitude peaks > of the set value, these will not be taken into account in the measurement.</p> <p>For example:</p> <p>Setting the value to 10%, a peak > 10% of full scale will be ignored by the device.</p>
Average measure	<p>Indicates the number of mediated samples which are used to manage the increase of the totalizers and pulse outputs.</p> <p>To increase the stability, increase the value in this sub-menu.</p>

MENU → PARAMETERS

Line frequency

It allows the setting of the local power supply frequency (50Hz o 60Hz) in order to minimize interference.

To read and change the filter values from the MC608 software program, access the screen "FILTERS" (Fig. 46) and change the filter values within indicated range.

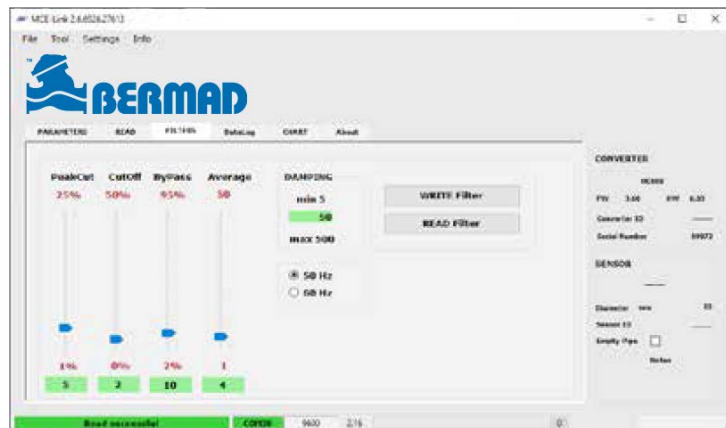

Fig. 46 Screen "FILTERS"

ZERO CALIBRATION

Used to perform zero calibration of the device. Before performing the zero calibration, ensure that:

1. The sensor is full of liquid
2. The liquid is perfectly stationary
3. The sensor has correct electrical grounding

FLOW RATE ALARMS

MAX flow rate

It allows the setting of the maximum flow rate value in percentage on the full scale value. This value is factory disabled. Selectable range starts from a minimum threshold of +5% up to 100% of the full scale value. To disable the feature, select > 100%

Min flow rate

It allows the setting of the minimum flow rate value in percentage on the full scale value. This value is factory disabled. Selectable range starts from 1% up to the maximum threshold of the full scale value.



When maximum and minimum flow rates are enabled, a symbol will be displayed on the screen in case these values are reached.





EMPTY PIPE THRESHOLD (available with sensors that have 4 electrodes)

Allows you to adjust the sensitivity of the empty pipe detection. Move the selection to "E" if the empty pipe alarm does not appear and to "F" if the alarm does not disappear with the full pipe.o.



To test the empty pipe detection, press the "test" button.

5.3.4 MENU → I/O

PULSE OUTPUT	
Pulse quantity	<p>It allows the selection of the pulse volume.</p> <p> For MC608B or MC608R converters, during the maximum flow rate of the process select a volume large enough so that the time interval between two consecutive pulses is greater than 1 second in order to preserve the battery life.</p> <p>On MC608 mains powered version</p> <p> Avoid pulse saturation, as this may lead to pulse accumulation which should not be provided in real time considering the actual flow rate.</p> <p>Calculation of the parameters (values must be reconsidered according to the technical units of the converter). $[V_p = \text{dm}^3 \text{ (litres)}, T_p = \text{seconds}; Q_{\text{max}} = \text{device maximum flow rate } \text{dm}^3/\text{s}]$ Set- table values for T_p are in a range from 0.001s to 2s.</p> <p>1) Once the time T_p has been set, the minimum volume V_p to be set is calculated as following $V_p > Q_{\text{max}} * 2T_p$;</p> <p>2) Once the volume V_p has been set, the maximum duration T_p to be set is calculated T_p, $T_p < V_p / (2 * Q_{\text{max}})$.</p> <p>If the calculated T_p value is lower than 0.001s (1ms), a higher value of V_p must be chosen so that the result is always $T_p \geq 0.001\text{s}$.</p> <p>On MC608B or MC608R battery powered version</p> <p> High pulse frequency will affect the battery life.</p> <p>Calculation of the parameters (values must be reconsidered according to the technical units of the converter). Settable values for T_p are in the range from 0.001 s to 0.1s.</p> <p>1) Once the time T_p has been set, the minimum volume V_p to be set is calculated as: $V_p > Q_{\text{max}} * 20T_p$;</p> <p>2) Once the volume V_p has been set, the maximum duration T_p to be set is calculated as: $T_p < V_p / (20 * Q_{\text{max}})$.</p> <p>If the calculated T_p value is lower than 0.001s (1ms), a higher value of V_p must be chosen so that the result is always $T_p \geq 0.001\text{s}$.</p>
Pulse time ON	<p>Select the ON time duration of the pulse on a range between 1 and 1999 ms.</p> <p> With MC608B select the pulse time ON no higher than 0.1 seconds (100ms).</p>
Reverse flow rate (off/ on)	<p>In case of negative flow, this function will enable/disable the pulses from the pulse output.</p>
Active pulse output	<p>Select to disable the frequency output and activate the pulse output (factory condition).</p>
FREQUENCY OUTPUT	
Full scale freq.	<p>Set the maximum frequency that corresponds to the full scale flow rate value. Selectable range: 100 Hz ... 10 kHz.</p>

MENU → I / O

Active output freq.

Select to disable the pulse output (which becomes PWM, pulse width modulation) and frequency enable output.

USCITA PROGRAMMABILE

It is possible to choose among the following options for the programmable output:

- Enabled/disabled
- Reverse Flow
- Max flow threshold
- Min flow threshold
- MAX/MIN flow threshold
- Dosing
- Excitation failure
- Empty Pipe
- All alarms

PROGRAMMABLE INPUT

It is possible to choose among the following options for the programmable input:

- Enabled/disabled
- Resetting p+
- Resetting p-
- Resetting p+/p
- P resetting and block



If the programmable output is set to “dosing,” the programmable input will be the same and automatically used in the option dosing and it cannot be changed.

DOSAGGIO

Set the volume to be dosed. Available only with MC608A.



In order to guarantee adequate precision, the dosing duration must be greater than 60 seconds with full speed flow.

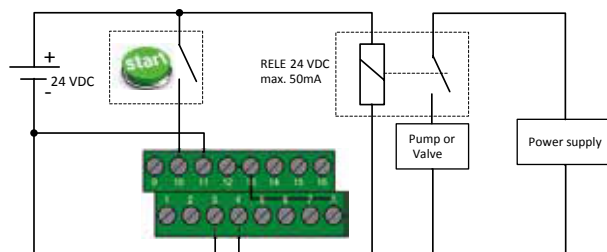

Fig. 47 Example of Connection for the Programmable Output

PROGRAMMABLE OUTPUT LOGIC

It is possible to change the logic of the programmable output by choosing between NO/NC – normally open, normally closed.





In battery mode the output is always NO.

5.3.5 MENU → OTHER

SYSTEM INFORMATION	
	Displays the information on the system. End user cannot change these values.
TIME / DATE	
	Displays time, date, motherboard temperature, power supply voltage.
RESERVED	
	Menu for the exclusive use of the manufacturer.
DIAGRAM	
	Displays the diagram of the measured flow rate.
SIMULATION	
	<p>MC608 converter has an integrated flow simulator which checks and sets the pulse output to any connected device system.</p> <p> When the flow simulator is being used, the counter values are not increased.</p>
COMMUNICATIONS	
Baud rate RS485	Allows for the adjustment of the RS485 baud rate in a range between 2400 and 115.700 bps.
MODBUS address	Allows for the adjustment of the address of the MODBUS communication in a range between 1 and 255.
DATA CONNECTION (RS485/IrCOM)	<p>Allows for the selection of the RS485 port or infra-red port for connection to pc.</p> <p>Before starting the infra-red communication, make sure that the function IrCOM of the converter has been enabled: Menu → Other → Communication → Data connection → IrCOM.</p>

5.3.6 MENU → MEMORY

UPLOAD USER'S COPY	
	Allows you to upload personalized settings.
SAVE USER'S COPY	
	Allows you to save personalized settings.
LOADING FACTORY SETTINGS	
	Allows you to load factory settings.
DATALOGGER	
Displays latest line	Displays the latest information logged: date, time, counter, instantaneous flow rate, temperature, battery status. Other stored information (i.e. temperature, process pressure) can be seen only if the data are downloaded.
Complete deletion	Deletion of the converter memory.
LOG interval	<p>Select the log interval. Minimum 1 minute / Maximum 120 minutes.</p> <p>In battery powered MC608B and MC608R versions, priority is determined by measurement interval: (LOGGING>=MEASUREMENT).</p> <p>To read and change information stored in the memory in the program of the MC608 converter, go to the screen "DATA LOG" (Fig. 48).</p> <p>Select the line START (see 1, Fig. 48) and END (see 2, Fig. 48) to read the button "restore latest log" (see 3, Fig. 48) which shows the latest available log.</p> <p>Press the READ button (see 4, Fig. 48) of the log to download the data.</p> <p>Press "SAVE CSV" (see 5, Fig. 48) to save the data on the PC in CSV format.</p> <p>Press the "Reset datalogger" button (see 6, Fig. 48) to fully reset the converter memory.</p> <p> Before proceeding to memory reset, make sure that all the data have been saved.</p> <p> Data registration interval can be changed in the main screen, in a range between 1 minute and 120 minutes.</p> <p style="text-align: right;">[continues]</p>

MENU → MEMORY

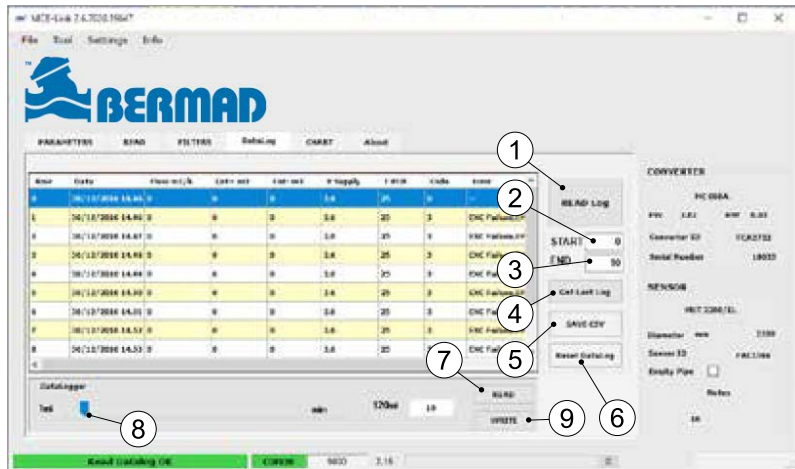

Fig. 48 LOG interval

To view the last line generated by the converter, select “Last log Settings.” The number of the last stored line will then be displayed. Then select “download log” to see the history of the available data. To save the data in a readable format in Excel, click on “save CSV.”

To change the data logger storage time, click on read (see 7, Fig. 48), and then use the horizontal scroll key between 1 and 120 minutes (see 8, Fig. 48) to change the storage time interval. Click on “Write” (see 9, Fig. 48) to apply the new data and make the change effective. After reading the data, selecting the DIAGRAM screen will show a flow rate chart (Fig. 49).

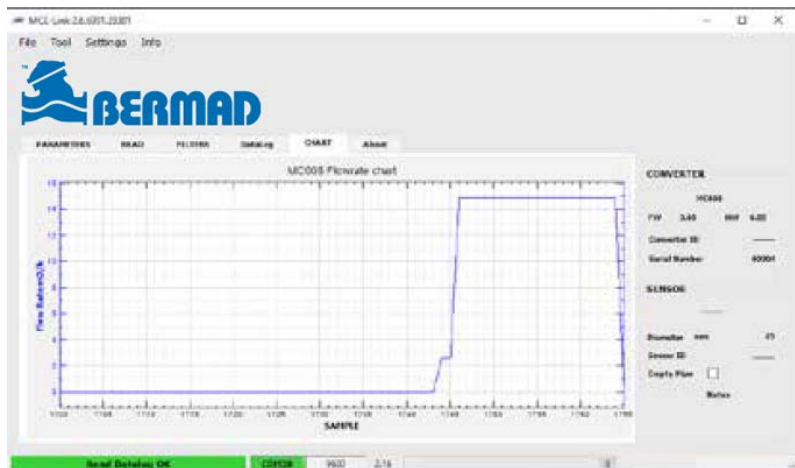

Fig. 49 Flow Rate Chart

KEY WORD SETTING



Allows you to change the three password levels.

To access the selection of the three passwords that you want to change (L1,L2,L3), the Level 3 password is required.

NEW BATTERY



After replacing the battery pack, select “new battery” to confirm the replacement.

6 MAINTENANCE

-  The converter is not equipped with moving parts and/or mechanical parts subject to wear and therefore does not require any ordinary maintenance except for the periodic check of the correct closure of the cable glands, the condition of the sealing gaskets of the covers (in all versions) and the replacement of the discharged battery (in the MC608B version).
-  The device (front panel and converter casing) can easily be cleaned with soft cloths and neutral detergents.

6.1 CABLE GLAND CLOSING AND GASKET CONDITION CHECK





Since the environmental characteristics where the converter is installed are not known in advance, it is not possible to provide univocal indications on how often periodic checks on cable glands and gaskets should be performed.

-  The operating experience of the user and the knowledge of the environmental characteristics of the converter installation location will allow the operator to decide how regular controls must be.
-  **Warning!** Converters that are positioned outdoors and/or in places/supports subject to vibrations can loosen the cable glands over time, so they must be checked/controlled more frequently than converters that are installed in closed environments and/or protected from external stresses.

CHECKS

- Perform periodical checks of the tightness of the cable glands and their condition.
- On this occasion, check the condition of the seal in the cover and, if provided, in the electrical junction box.
- Finally, check that all the electrical cables are correctly affixed to the relative terminals, that they are physically intact and that they do not show signs of deterioration.

6.2 BATTERY INSTALLATION/REPLACEMENT ON MC608B/R

-  The battery pack is usually supplied SEPARATELY from the converter, therefore, before the MC608B (and MC608R) is put into operation, the battery pack must be inserted in its housing and connected to the instrument according to the instructions provided below.
-  **NOTE:** The operations described below are also valid for the replacement of the battery, which is necessary to perform when the status icon "" indicates a low charge level on the MC608B display.
-  **NOTE:** Under normal operating conditions, the battery life can last up to 10 years. Any changes to the settings and programming of the converter (see paragraph 5.3) can affect the battery life.

BATTERY INSTALLATION/REPLACEMENT

1	<p>Insert the battery pack (see 1, Fig. 50) into the battery holder (see 2, Fig. 50) so that the power cable (see 3, Fig. 50) comes out of the bottom of the holder.</p> <p>When inserting the battery pack, be careful to match the grooves on the battery to the anti-rotation stops provided on the holder.</p>	
2	<p>Connect the battery pack (see 1, Fig. 51) to the electronic board of the converter (see 2, Fig. 51) by inserting the 5-ways connector (see 3, Fig. 51) to the relative counterpart.</p>	
3	<p>Insert completely the battery pack (see 1, Fig. 52) inside the appropriate housing of the converter (see 2, Fig. 52).</p> <p>Make sure that the O-ring seal positioned on the cover thread (see 3, Fig. 52) is in its place and in good condition (if necessary, replace it).</p>	
4	<p>Put on the cover (see 1, Fig. 53), close the battery pack and screw it to the end of the stroke by pressing lightly the O-ring seal to guarantee the insulation.</p>	
5	<p>Only in case of battery replacement, confirm the replacement by clicking the item "new battery" accessible from the menu "MEMORY."</p>	

7 TROUBLESHOOTING

7.1 MALFUNCTIONING AND POSSIBLE SOLUTIONS



The following table summarizes the possible malfunctions that may occur during the use of the MC608 converter, for which the possible causes and solutions to be adopted in order to restore correct operation of the flowmeter are listed.

MALFUNCTIONING	POSSIBLE CAUSE	SOLUTION
The converter shows a flow rate even when there is no flow.	Grounding missing or incorrect.	Check that the sensor and the liquid are correctly grounded, making sure that the relative earth ground connections are correctly connected.
	Lack of liquid in the sensor downstream of the converter.	Check that the sensor is full with liquid.
	Electric conductivity of the liquid is too low or it is not compatible with the material used for the sensor electrodes.	Check which electrode type is used on the sensor. If necessary, replace electrodes and/or sensor.
	Calibration missing or incorrect.	Perform manual zero calibration if necessary (Menu - Parameters, submenu - zero calibration).

MALFUNCTIONING	POSSIBLE CAUSE	SOLUTION
External pulse totalizer shows results different than expected.	Pulse output configuration error.	Check the conditions in the paragraph 5.3.4 - menu – Pulse output. Test the output with the external flow simulator and the converter-pulse counter system, simulating a flow rate through System > Simulation.







MALFUNCTIONING	POSSIBLE CAUSE	SOLUTION
The screen is turned off and it doesn't turn on.	There is no voltage supply or it is incorrect.	Check the current supply voltage on the converter plate.
		For the MC608B version, check the battery life and replace the battery pack.

MALFUNCTIONING	POSSIBLE CAUSE	SOLUTION
The flow reading is very unstable.	Caused by HYDRAULIC failure: Air bubbles or unstable flow (vortex motion). The minimum required linear distances upstream and downstream of the device were not complied with.	Check for the minimum required linear distances upstream and downstream of the device. Check for the presence and correct installation of vents on the pipe to avoid the presence of air in the pipe.
	Caused by ELECTRIC failure: Grounding missing or performed improperly, oxidized nodes, very noisy ground point, usually in common with the grounding systems of pumps or inverters.	Change the grounding point or preferably create a new one for the exclusive use of the meter.
	NOTE: If with full pipe and stable liquid an unstable reading can be observed (which varies rapidly) then most likely it is a problem of electrical noise. Only if necessary, set the filters in the following way: <ul style="list-style-type: none"> • Set the damping to 150 • Reduce the peak cut off filter • Increase the bypass filter 	

7.2 ALARM MESSAGES SOLUTION



In this paragraph you will find the alarm messages that can be shown on the display when the relative status icon appears. Each alarm message is accompanied by possible causes that generated it and the possible solutions to be applied in order to restore the correct functioning of the flow meter.

ALARM ICON	CAUSES AND POSSIBLE SOLUTIONS
 [Interrupted excitation]	<ul style="list-style-type: none"> • Incorrect or damaged electrical connection to the sensor/ converter. • Sensor damaged. Possible seepage inside the sensor. • Converter damaged. <p>In case of remote configuration check for the electrical connections of separation cables.</p> <p>Refer to the procedure "DI10D_SENSORTEST" available in the download area of the website www.bermad.com to check the electrical continuity of the sensor coil circuit.</p>
 [Measure error]	<ul style="list-style-type: none"> • Empty pipe. • Air bubbles in the liquid. • Incorrect grounding. • Incorrect or damaged electrical connection to the sensor/ converter. <p>Check if the sensor has been installed correctly and if there is an air inside the pipe.</p> <p>Make sure that the sensor and converter are properly grounded. In case of remote configuration check for the electrical connections of separation cables.</p> <p>Refer to the procedure "DI10D_SENSORTEST" available in the download area of the website www.bermad.com to check for electrical insulation inside the sensor.</p>
 [Empty pipe]	<ul style="list-style-type: none"> • Empty pipe detection. <p>This message is displayed with sensors that have 4 electrodes. Indicates the alarm of empty pipe, or even only partially empty. In case of persistent message with full pipe (more than a few minutes), check for the electrical connections of separation cables (remote version).</p> <p>Work on the empty pipe threshold (see EMPTY PIPE THRESHOLD on page 39).</p>
 [Pulses accumulation]	<ul style="list-style-type: none"> • Incorrect pulses frequency <p>We recommend to change the settings of the pulse volume and duration (see "PULSES OUTPUT 58" on page 44).</p>
 [Power supply voltage]	<ul style="list-style-type: none"> • Supply voltage out of operating range <p>Check the power supply network. Move the antenna to a more favorable position.</p>
 [Low GSM signal]	<ul style="list-style-type: none"> • Low or missing GSM signal. <p>Check the antenna connection.</p>

8 SENDING THE CONVERTER (COMPACT VERSION) TO THE MANUFAC

The device was manufactured with extreme care and passed rigorous tests before shipment from the factory. If the installation and maintenance are carried out correctly, it is very unlikely that malfunction will occur.

However, if it should be necessary to send the device to our customer service for any checks or repairs, please pay attention to the following points:

- According to the legal provisions on environmental protection and securing the health and safety of our personnel, the manufacturer can only test and repair those devices returned to us that have been in contact with products that are risk-free for personnel and environment.
- This means that the manufacturer can perform the service on the device only if this is accompanied by the "Repair request form" stating that the device itself (in the COMPACT version) can be safely handled.

8.1 REPAIR REQUEST FORM



The "repair request" form shown below on the following page must be photocopied, filled in and attached to the device that needs to be checked/repared by our customer service.

9 PRODUCT DISPOSAL

If you decide to put the converter out of service because it is definitely no longer in use, disconnect it from the electrical power source (MC608A) and from the connection cables to the sensor before proceeding to its removal and its disposal.

Disposal of the device is the responsibility of the user who must comply with the specific laws enforced in the country of installation regarding environmental protection.

MANUFACTURER'S STATEMENT

The manufacturer declares that the design, development and construction of the CONVERTER have been carried out in compliance with the directive on the reduction of the use of dangerous substances with particular attention to waste electrical and electronic equipment (WEEE) supporting, from an environmental point of view and the protection of the health of the worker, the intervention of the subjects who participate in the installation, use and disposal of their products (manufacturer, distributors, consumers, operators involved in WEEE treatment).

The crossed-out wheelie bin symbol (Fig. 54) contained on the equipment indicates that the product must be collected SEPARATELY from other waste at the end of its useful life.

Therefore, the user must give the equipment at the end of its life to the appropriate waste collection centers for waste electrical and electronic equipment, or return it to the retailer when purchasing a new equivalent type of equipment.

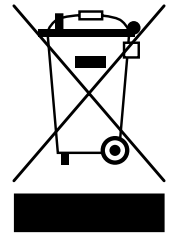

Fig. 54

Appropriate sorted waste collection for the next start-up of the disused equipment for recycling, treatment and environmentally compatible disposal contributes to avoiding possible negative effects on the environment and favors the reuse and/or recycling of the materials of construction. Unauthorized disposal of the product by the user results in the application of the administrative sanctions provided for by applicable law.