

DIRECT ACTING PRESSURE REDUCING VALVE

Model DPRV-CAP1

Spring loaded, direct acting pressure reducing valve that reduces a high upstream pressure to a lower downstream pressure. The pre-calibrated device is easily adjustable using an adjustment knob with setting indicator. This model is often used as a low flow bypass on larger piloted pressure reducing valves like the BERMAD 720-2B or 420-2B. The BERMAD DPRV CAP1 is certified to meet EN 1567 and ASSE 1003 performance standards. Additionally, these valves are approved for potable water applications in compliance with WRAS, NSF 61, NSF 372, and other relevant certifications.

Features

- Pre-assembled, self-contained cartridge with all adjustment components for quick, easy in-line replacement.
- Low-friction internal components minimize lime scale buildup and reduce risk of malfunctions.
- Balanced compensation chamber ensures stable downstream pressure despite upstream fluctuations.
- Compact Y-pattern design delivers high capacity.

Typical Applications

- Low flow bypass for pilot-operated PRV.
- Ideal for reducing pressure in single-floor or single-house applications.

Technical Data

General:

End connections: Threaded Male Union according to EN 10226-1

Pressure Gauge (optional): ¼" F (ISO 228-1)

Max Inlet Pressure:

25 bar (static, EN 1567)

16 bar (working, EN 1567)

Downstream Pressure Setting Range: 1–6 bar (static)

Working Temperature: Up to 80°C

Medium: Water

EN 1567 Acoustic Group: II (½"–1¼")

Main Valve Materials:

Body: dezincification resistant alloy EN 12165 CW724R

Cover: PA6G30

Internals:

Control Stem: stainless steel EN 10088-3 (AISI 303)

Moving Parts: dezincification resistant alloy EN 12165 CW724R

Diaphragm: EPDM

Seals: EPDM

Strainer: stainless steel EN 10088-2 (AISI 304)

Seat:

(½"–1") PPSG40

(1¼"–2") stainless steel EN 10088-3 (AISI 303)

Cartridge: PPSG40

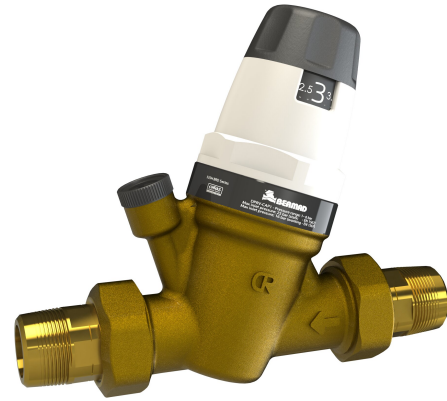

Sizing Guidelines

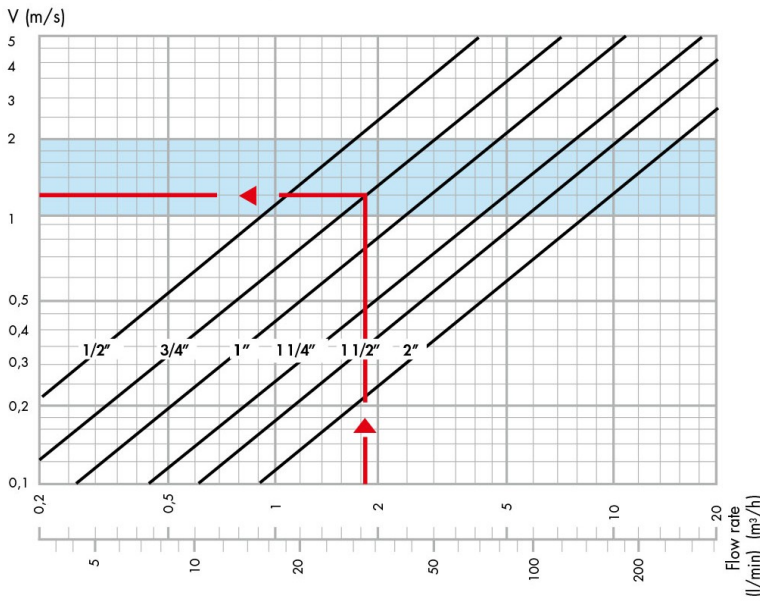

To ensure optimal system performance, it is recommended to maintain the flow velocity within 1 to 2 m/s, as shown in the blue zone of the bend.

Example:

For 33 l/min, select a DN20; 3/4" diameter (see arrow on graph).

Pressure Drop

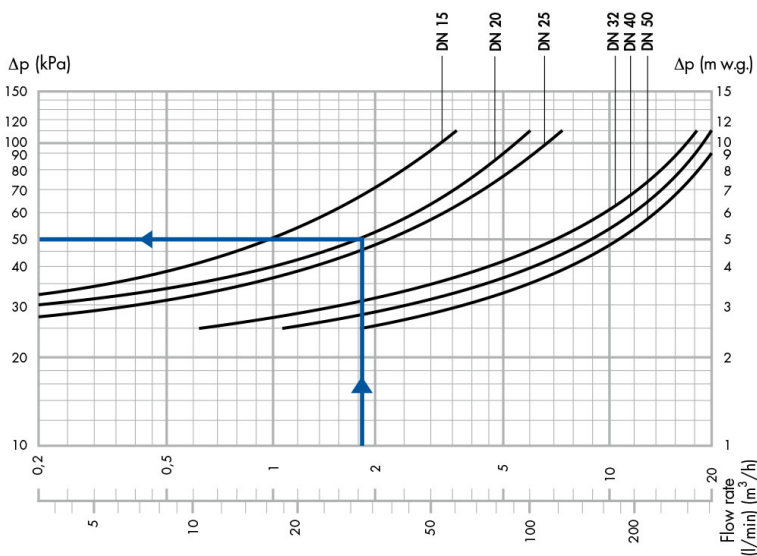

Pressure setting is established under no flow (static) conditions. As flow increases, the set pressure decreases according to the curve shown in graph 2.

Example:

At a flow of 33 l/min the set pressure drop is approximately 0.50 bar (see arrow on the graph).

In other words, if the downstream pressure is set to 3.0 bar under static conditions, the expected pressure at a flow of 33 l/min will be approximately 2.5 bar.

Dimensions and Weights

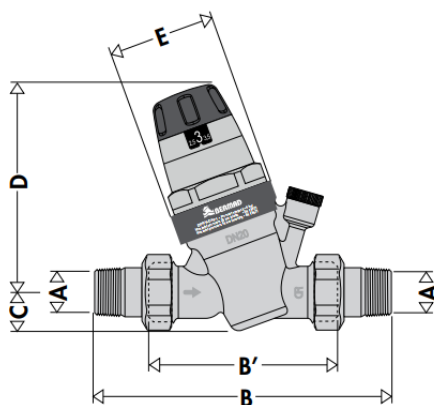

DN	A	B	B'	C	D	E	Weight (Kg)
15	1/2"	140	76	20.5	115	Ø60	0.86
20	3/4"	160	90	20.5	115	Ø60	1.02
25	1"	180	95	20.5	115	Ø60	1.31
32	1 1/4"	200	110	40	178	Ø78	2.78
40	1 1/2"	220	120	40	178	Ø78	3.30
50	2"	250	130	40	178	Ø78	4.41

Dimensions in millimeters