



## 2-Way Hydraulic Relay Valve

### Model: HRV-2 Type B

The BERMAD HRV-2 is a 2-Way hydraulic pressure operated relay valve, used for the release and opening of BERMAD deluge valves. The HRV-2 will close in response to pressure being supplied to its control chamber, keeping the deluge valve closed.

Upon pressure release from the control chamber the HRV-2 will open, facilitating a quick opening response of the main deluge valve.

The HRV's simple design enables safe reliable operation with a low control pressure with compact dimensions.

The HRV-2 has been specifically designed for Fire Safety systems in that it has no mechanical friction of the internal parts, greatly increasing reliability. This also makes it ideal for use with corrosive fluids such as firewater, brackish or seawater.

The HRV-2 Type B incorporates two outlet connections, enabling either a straight or an angular flow configuration.



Standard SS316 Construction



NAB Construction / Optional Materials

### Features and Benefits

- Frictionless operation: increases safety and reliability, well suited for use with sea-water and corrosive fluids
- Heavy duty construction: Suitable for the harsh conditions of chemical and offshore facilities
- Corrosion resistant construction materials

### Models and Material Selection

#### Model HRV-2-N-B SS316 Construction

- Body: ASTM A351 Gr. CF8M Type 316
- Cover: ASTM A351 Gr. CF8M Type 316
- Elastomers: NBR
- Internals: Stainless Steel 316
- Spring: Stainless Steel 316

#### Model HRV-2-U-B NAB Construction

- Body: Ni-Al-Bronze ASTM B171 C63000
- Cover: Ni-Al-Bronze ASTM B171 C63000
- Elastomers: NBR
- Internals: Ni-Al-Bronze
- Spring: Hastelloy C276

### Optional Materials

- Super Duplex 25Cr
- Hastelloy
- Titanium

### Technical Data

#### Orifice

- 9 mm (0.354")

#### Pressure Rating

- 25 bar (365 psi)

#### Temperature

- Water up to 80°C (180°F)

#### Flow factor

- KV 1.7 (CV 2.0)

#### Port Connections

- Line pressure 3/8" NPT, Control 1/4" NPT

#### Approvals

- UL-Listed and FM Approved when installed on specific BERMAD valve models

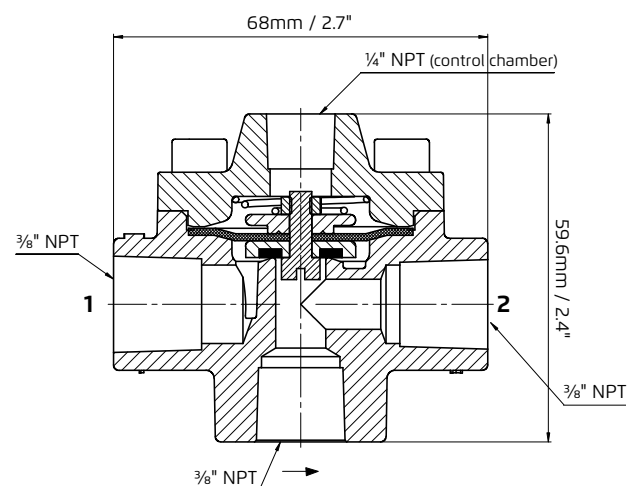

Weight: 0.6 kg / 1.3 lbs.